

SICERA™ CRYOPUMP

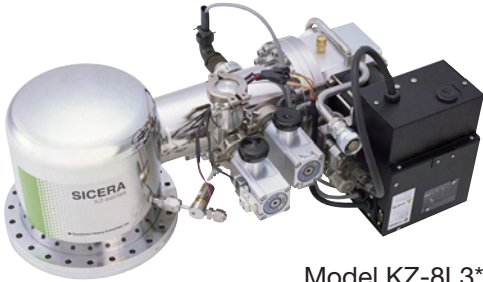

Model KZ-8L3*

Starting at only 0.9kW per pump, the SICERA™ cryopump features low energy consumption compared with other vacuum products currently available for semiconductor, flat panel display and related processing. SICERA utilizes SHI proprietary inverter technology to reduce customer energy costs 20-30%. The breakthrough multi-pump system allows up to six 8-inch pumps to run on a single compressor without performance degradation, making it ideal for high-volume semiconductor wafer manufacturing.

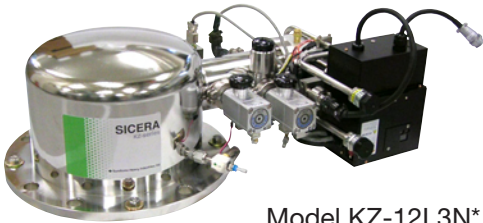

Model KZ-12L3N*

The complete SICERA cryopump system includes a compressor and remote controller, which have been thoroughly tested to withstand the most demanding vacuum applications. Through continuous control of both the cryocooler and compressor, SHI Cryogenics Group is able to offer a reliable cryopump system with significant energy savings, as well as excellent temperature and vacuum stability.

Features

- Extremely low energy consumption
- Real multi-pump system
- Fully automated regeneration
- Robust and solid performance
- Supported by a worldwide sales and service network

Specifications

Models:		KZ-8L3 (8 inch)	KZ-12L3N (12 inch)
Pumping Speeds:	Air	1500 L/sec	3300 L/sec
	Water	4000 L/sec	9500 L/sec
	Argon	1250 L/sec	2700 L/sec
	Hydrogen	2200 L/sec	6000 L/sec
Throughput:	Argon	8.86 torr-liters/sec (700 sccm)	8.86 torr-liters/sec (700 sccm)
Capacity:	Argon	1000 standard liters	2000 standard liters
	Hydrogen	12 standard liters	30 standard liters
Crossover Rating:		150 torr-liters	150 torr-liters
Regeneration Time:		120 minutes	150 minutes
Power Consumption:		0.9 kW/pump	1.5 kW/pump

* Complete system includes a compressor and remote controller, not shown

Real Multi-Pump System

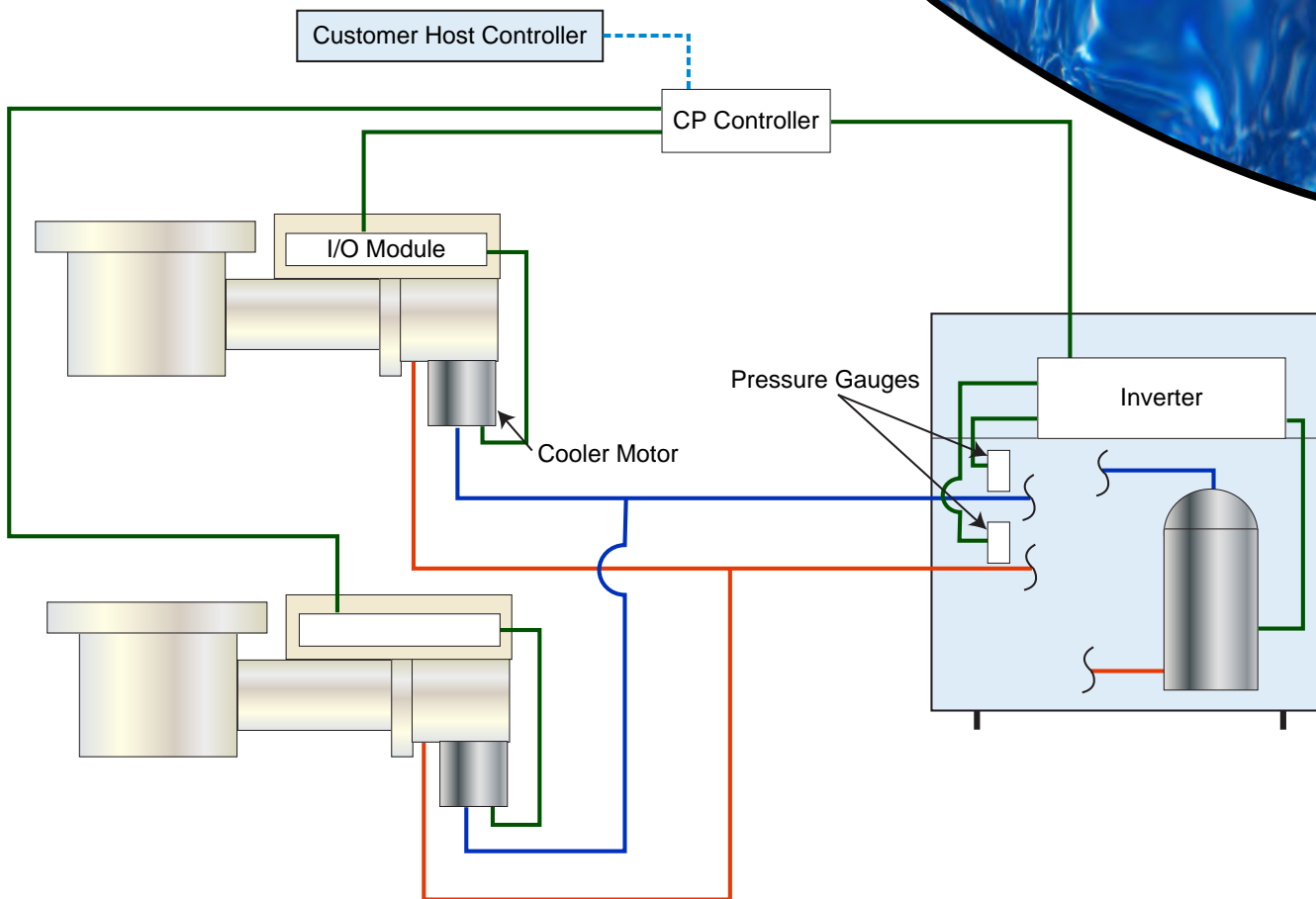

For Information in: Asia

Sumitomo Heavy Industries, Ltd.
ThinkPark Tower
Cryogenics Division, Sales Department
1-1, Osaki 2-Chome, Shinagawa-Ku
Tokyo 141-6025, Japan
Phone: +81-3-6737-2550
Fax: +81-3-6866-5114
E-mail: cryo@shi.co.jp

Sumitomo Heavy Industries (Shanghai), Ltd.
Room 1301, Xingdi Business Building
1698 Yishan Road, Minhang District
Shanghai 201103, P.R. China
Phone: +86-21-3462-7660
Fax: +86-21-3462-7661
E-mail: Jin-Lin_Gao@shi.co.jp

SHI Cryogenics of Korea Co., Ltd.
Room 619-620, Venture Valley
#958 Goseck-Dong, Kwonsun-Gu
Suwon-City, Gyeonggi-Do, South Korea
Phone: +82-31-278-3050
Fax: +82-31-278-3053
E-mail: Won_Bum_Lee@shi.co.jp

Europe

Sumitomo (SHI) Cryogenics of Europe, Ltd.
3 Hamilton Close, Houndmills Industrial Estate
Basingstoke, Hampshire RG21 6YT
United Kingdom
Phone: +44 (0) 1256 853333
Fax: +44 (0) 1256 471507
E-mail: uksales@shicryogenics.com

Sumitomo (SHI) Cryogenics of Europe, GmbH
Daimlerweg 5a
Darmstadt D-64293, Germany
Phone: +49 (0) 6151 860 610
Fax: +49 (0) 6151 800 252
E-mail: contact@sumitomocryo.de

World Wide Web: www.shicryogenics.com

United States

Sumitomo (SHI) Cryogenics of America, Inc.
1833 Vultee Street
Allentown, PA 18103
Phone: +1 610-791-6700
Fax: +1 610-791-0440
E-mail: sales@shicryogenics.com

Sumitomo (SHI) Cryogenics of America, Inc.
456 Oakmead Parkway
Sunnyvale, CA 94085
Phone: +1 408-736-4406
Fax: +1 408-736-7325

Sumitomo (SHI) Cryogenics of America, Inc.
1500-C Higgins Road
Elk Grove Village, IL 60007
Phone: +1 847-290-5801
Fax: +1 847-290-1984

© SHI Cryogenics Group 10/09