

Chambers *Standard and Custom*

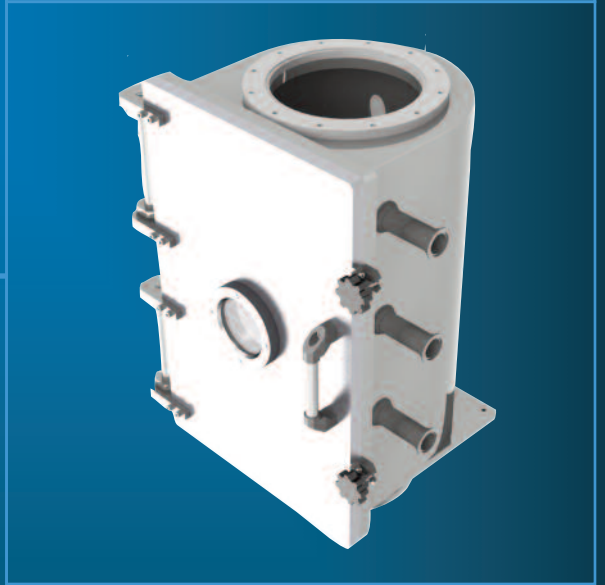
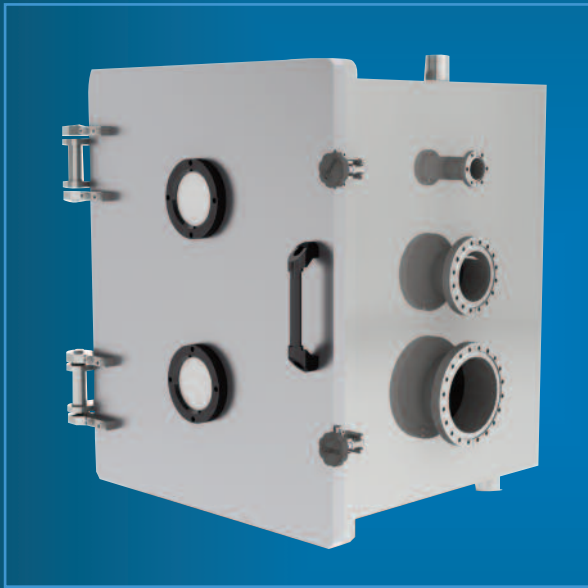

MDC

engineered process solutions

- **MDC's New Standard Line of Chambers consists of Spherical, D-Shaped, Cylindrical and Box Configurations**
- **Available in Stainless Steel and Aluminum**
- **Supplied with Electropolished surface finish**
- **Mounting Bosses**
- **Optional Support Frame**



Chambers

Introduction	2
Standard Chambers	
Spherical	4
D-Shape	6
Cylindrical	8
Box	10
Chamber Support Frames	12
Surface Science Analysis	14
Bell Jar Systems	16
Stainless Steel Bell Jars	18
Feedthrough Collars	20
Baseplates	22
Base Wells	22
Custom Engineering	
Chamber Geometry	26
Modifications to Standard Parts	28
Ordering Information	30



Standard 16" Spherical Chamber

Description

MDC Standard Spherical Chambers are versatile and designed to be suitable for a wide range of analytical studies and experiments.

Available in either a 12" or 16" nominal diameter they are constructed from 304L stainless steel. Both versions feature a variety of access ports of different sizes to accommodate connection to a variety of experimental devices, analytical instruments, viewports, electrical and motion feedthroughs, vacuum measurement gauge tubes as well as other accessories.

All 2-3/4 inch Del-Seal™ flanged ports are connected to the chamber with oversized 1-3/4 inch outside diameter tubing to provide maximum apertures and allow the installation of larger devices. All access ports are precision aligned with a helium-neon laser during construction.

Fastening and sealing hardware, including copper gaskets and bolt sets, are found under the individual size flange in the Flanges & Fittings section of the MDC catalog or on the website.

ULTRAHIGH VACUUM SERIES

We offer the following sizes as Standard

- 12" O.D.
- 16" O.D.

Standard Features

- 12" or 16" nominal diameter x 1/8" wall
- 304L stainless steel construction
- Electropolished surface finish for UHV service
- Flange ports are non-rotatable Del Seals with thru bolt holes
- All ports target chamber center
- Bakeable to 400°C
- Frame mounting brackets

Standard Options

- Replace Del-Seal™ ports with ISO or add additional ports
- Support Frame with leveling feet, p/n 220002
Frame options available
 - Swivel casters & leveling feet
 - Working surface & lower shelf
 - Instrumentation mounting rack

Port Specifications

- 12" Chamber – Del Seal™ Ports

4x	1.33"	Equally spaced, bottom hemisphere
4x	2.75"	Equally spaced, top hemisphere
2x	4.50"	Front and back
3x	6.00"	Top and sides
1x	8.00"	Bottom
- 16" Chamber – Del Seal™ Ports

8x	2.75"	Equally spaced, both hemispheres
2x	6.00"	Front and back
3x	8.00"	Top and sides
1x	10.00"	Bottom



12" Spherical Chamber

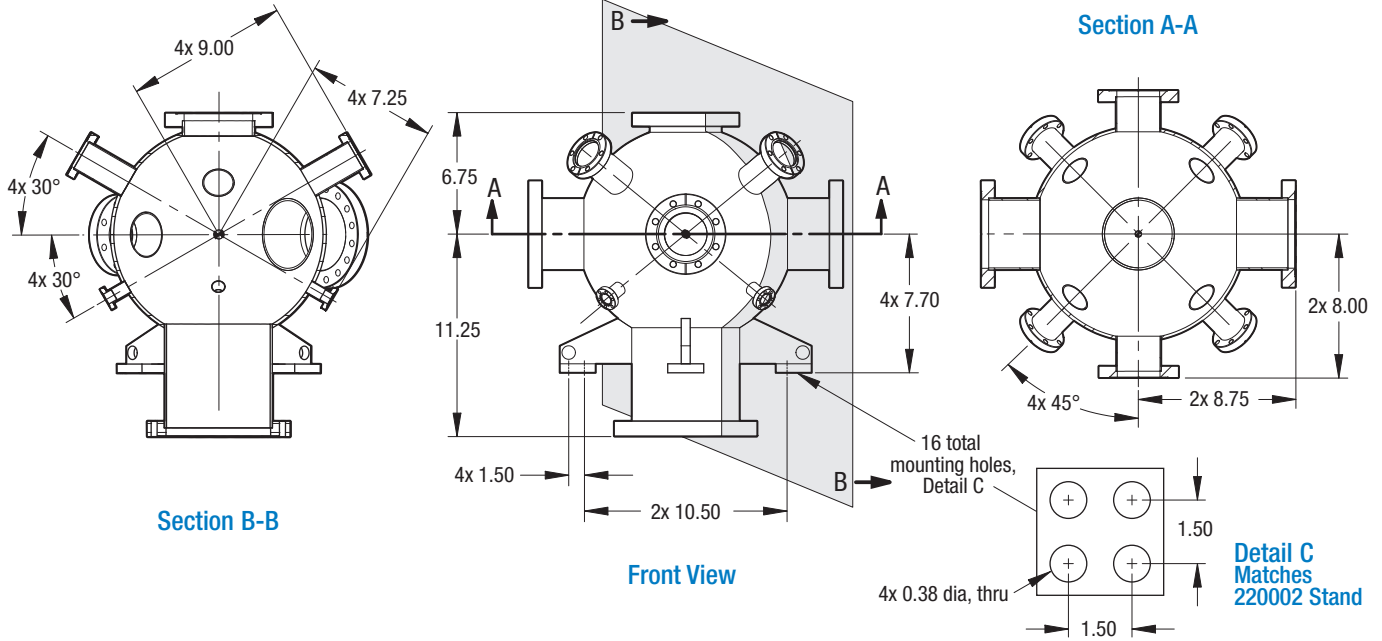

16" Spherical Chamber

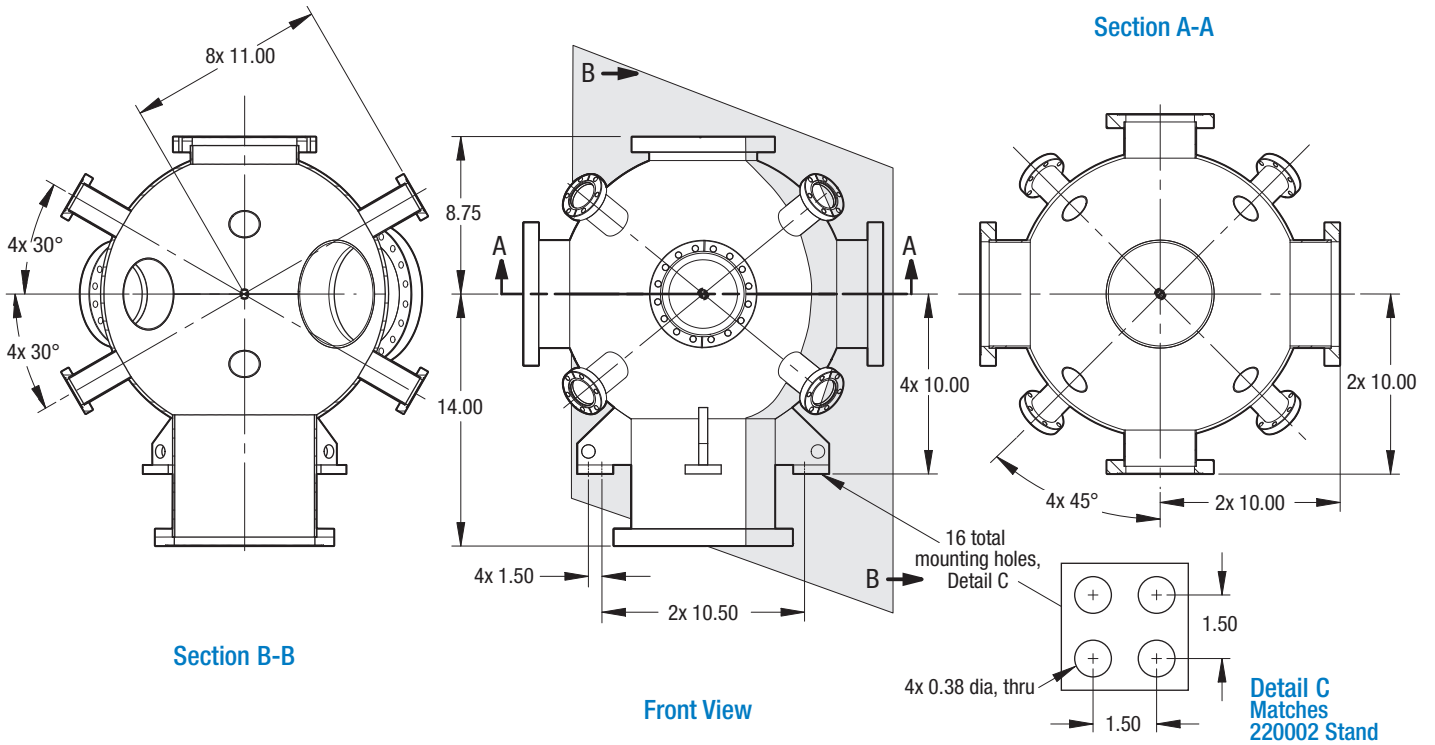

DESCRIPTION	WT LB	REFERENCE	PART NUMBER
12" DIAMETER SPHERICAL CHAMBER	53.5	CHAM-S-12	220000
16" DIAMETER SPHERICAL CHAMBER	83	CHAM-S-16	220001



Standard D-Shape Chamber

Description

MDC's Standard D-Shape Chambers offer versatility for a wide range of applications where full access to the chamber interior is readily available.

The standard design is 16-inches wide by 26-inches tall and features a semicircular back with an 8-inch radius. When viewed from above, the chamber has a distinctive D-shape. The chamber body and ports are 304L stainless steel and the door is constructed from 6061-T6 aluminum. The hinged door has a captured Viton® O-ring for a high vacuum seal and provides a quick opening door with full access to the entire chamber interior.

A variety of ISO KF & LF flanged ports accommodate connections for a number of devices such as pumps, analytical instruments, viewports, electrical or motion feedthroughs, vacuum measurement gauges and other accessories.

The chamber has four mounting feet with standard 1/2-13 UNC-2B threads for securing to Chamber Stand 220008 found on page 12.

Fastening and sealing hardware, including O-rings and ISO clamps, are found under the individual size flange in the Flanges & Fittings section of the MDC catalog or on the website.

HIGH VACUUM SERIES

We offer the following sizes as Standard

- 16" W X 26" H X 15" DP ID

Standard Features

- 304L Stainless Steel body
- Electropolished surface finish
- Aluminum hinged door for easy access to interior
- Frame mounting feet

Standard Options

- Support Frame with leveling feet, p/n 220008
Frame options available
 - Swivel casters & leveling feet
 - Working surface & lower shelf
 - Instrumentation mounting rack
- Trace water-cooling
- Alternate sizes can be configured
- Alternate port sizes available

Port Specifications

■ ISO KF & LF Ports

3x	NW40 KF	Right hand side
1x	NW63 LF	Back top
1x	NW100 LF	Back bottom
1x	NW200 LF	Bottom
1x	NW250 LF	Top
1x	4" Viewport	Door



D-Shape Chamber

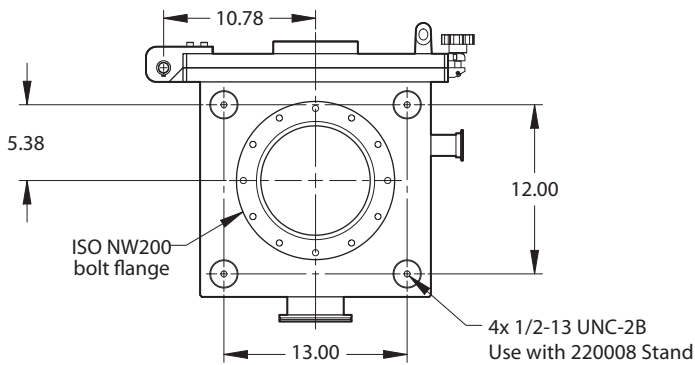
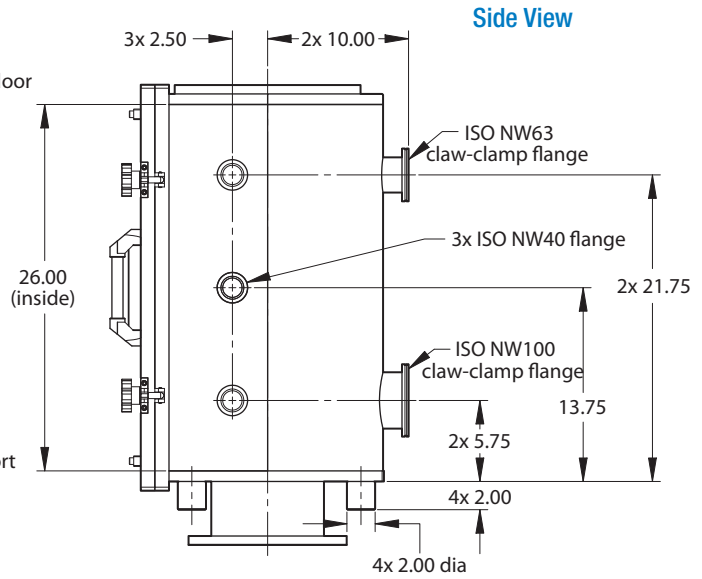
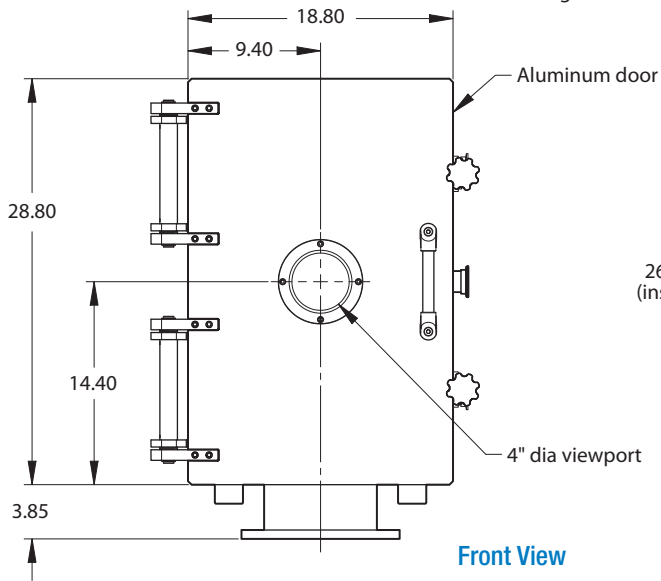
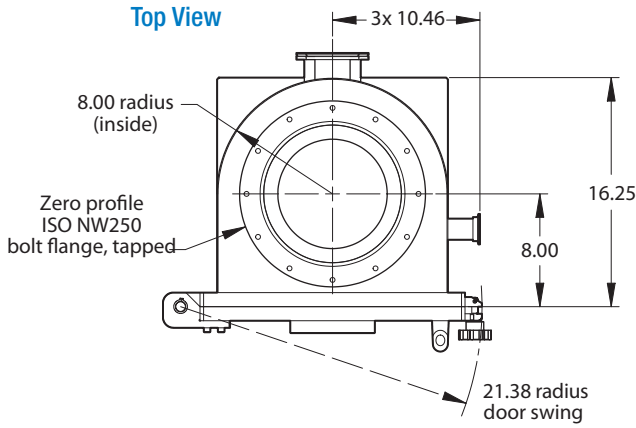
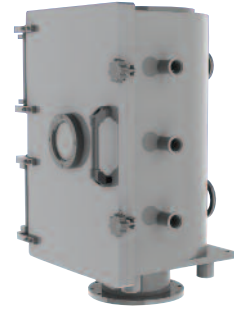

Bottom View

DESCRIPTION	WT LB	REFERENCE	PART NUMBER
STANDARD D-SHAPE VERTICAL MOUNT CHAMBER, NOMINAL INTERNAL DIMENSIONS 16" W X 26" H X 15" DP	270	CHAM-D-16	220006



Standard Cylindrical Chamber

Description

MDC's Standard Horizontal Cylindrical Chambers offer versatility for a wide range of applications where this is the desired configuration to meet the application need.

The standard designs are a 24" diameter vessel constructed from 304L stainless steel and an 18" diameter vessel constructed from 6061-T6 aluminum. Both versions feature a Viton® sealed quick opening hinged door for easy access to the interior of the chamber. A variety of different size access ports have been added to accommodate connections for a number of devices such as pumps, analytical instruments, viewports, electrical and or motion feedthroughs, vacuum measurement gauges and other accessories.

The stainless steel chamber is offered with Del-Seal™ metal sealing flanged while the aluminum version is offered with ISO KF & LF port flanges. Both versions are engineered to include support feet to facilitate simple mounting to one of our standard frames or directly to your working surface.

MDC's standard cylindrical chambers are designed for high vacuum service but the stainless steel version can easily be configured for UHV service by replacing the Viton® sealing front door with a wire sealing flange and changing the O-ring viewport to a Del-Seal™ flanged viewport. All sealing flanges and machined components have a standard 64 micro-inch surface finish. Seal surfaces are machined with a 32 micro-inch concentric finish suitable for vacuum applications.

Fastening and sealing hardware can be located under the individual size flange in the Flanges & Fittings section of the MDC catalog or on the website.

ULTRAHIGH & HIGH VACUUM SERIES

We offer the following sizes as Standard

- 24" Cylindrical Stainless Steel Chamber
- 18" Cylindrical Aluminum Chamber

Standard Features

- 24" body constructed from 304L stainless steel
- 18" body constructed from 6061-T6 aluminum
- Electropolished surface finish
- Hinged door for quick and easy access to interior
- Frame mounting feet

Standard Options

- Support Frame with leveling feet, p/n 220008
Frame options available
 - Swivel casters & leveling feet
 - Working surface & lower shelf
 - Instrumentation mounting rack
- UHV configuration with wire sealing front door and metal flanges (stainless steel version only)
- Double jacket water-cooling of the main cylinder
- Vertical orientations can also be configured
- Smaller or larger cylindrical diameters can be configured
- Alternate port options and locations available

Port Specifications

- 24" Stainless Steel Chamber – Del-Seal™ Ports

2x	2.75"	Top
2x	6.00"	Sides
2x	8.00"	Sides
1x	10.00"	Bottom
1x	4" Viewport	Door
- 18" Aluminum Chamber – ISO KF & LF Ports

3x	NW40 KF	Top
2x	NW100 LF	Sides
2x	NW200 LF	Sides
1x	NW250 LF	Bottom
1x	4" Viewport	Door



24" Cylindrical Chamber

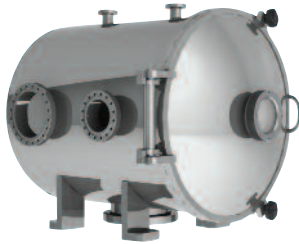

Side View

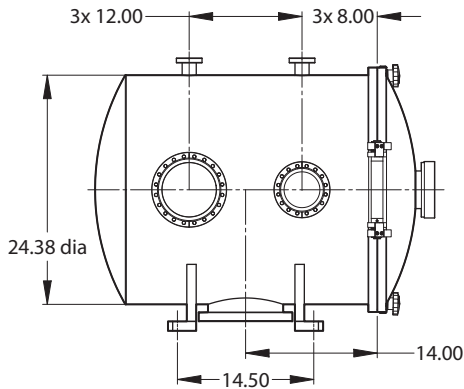

Top View

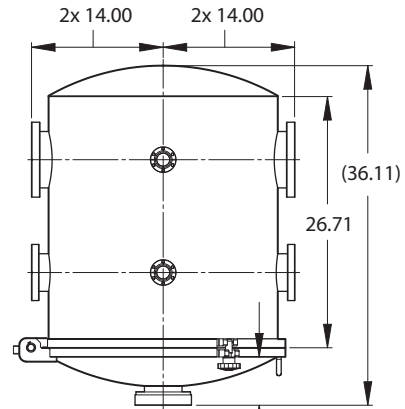

Front View

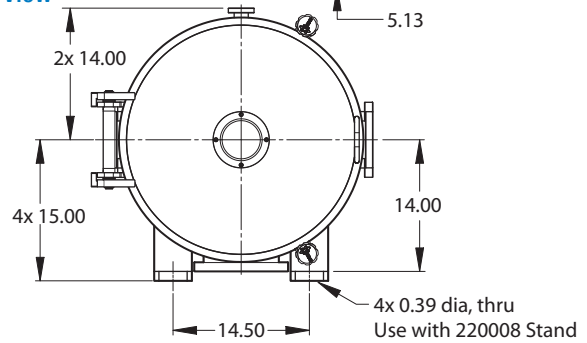

18" Cylindrical Chamber

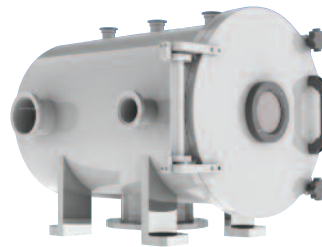

Top View

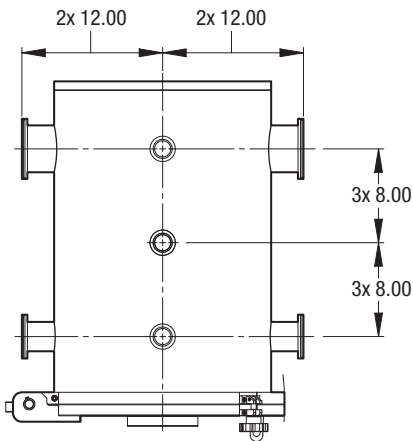

Front View

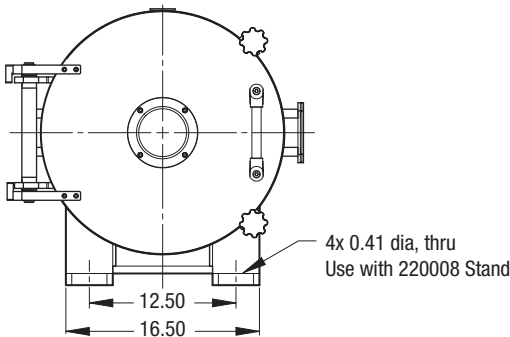

Side View

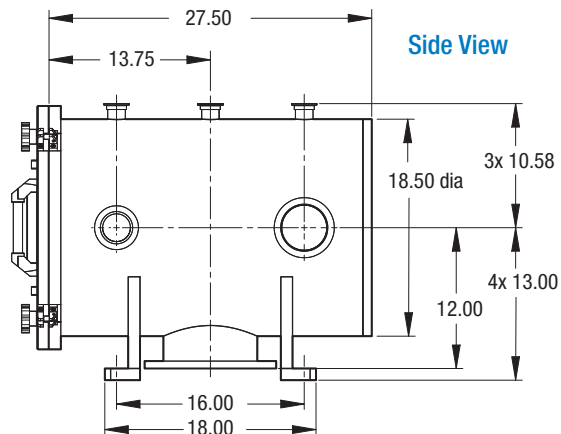

DESCRIPTION	WT LB	REFERENCE	PART NUMBER
24" CYLINDRICAL CHAMBER - STAINLESS STEEL	255	CHAM-CS-24	220005
18" CYLINDRICAL CHAMBER - ALUMINUM	132	CHAM-CA-18	220007

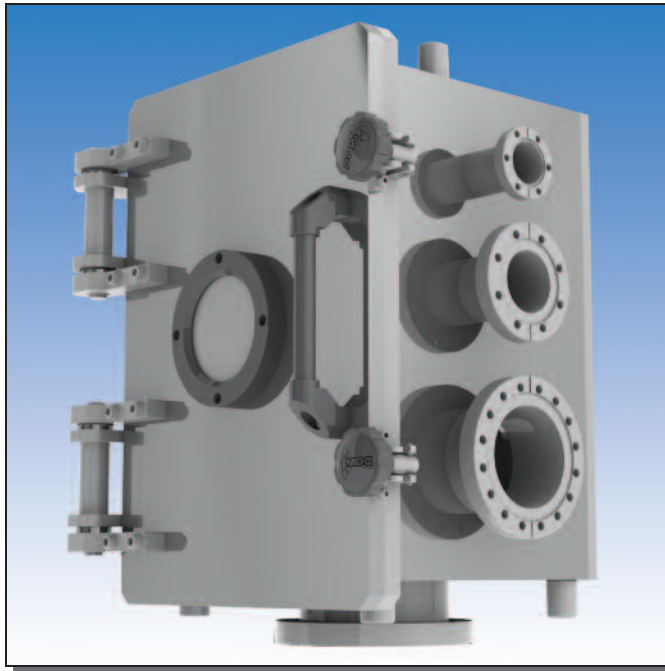

Standard Box Chamber

Description

MDC Standard Box Chambers are offered in two size configurations. Both offer quick access to the inside via a hinged access front door. The doors are constructed out of light weight aluminum and are O-ring sealed. These chambers are versatile in design and can be used for a wide range of deposition applications, analytical studies as well as other research related experiments.

Box chambers are available in either a 12" sq x 18" tall or 24" sq x 30" tall configuration. They are constructed from 304L stainless steel. Both versions feature a variety of access ports of different sizes to accommodate connection to a variety of experimental devices, analytical instruments, viewports, electrical and motion feedthroughs, vacuum measurement gauge tubes as well as other accessories.

Box chambers are welded out of plate stock thick enough to avoid deflection. The plates are surface ground or mechanically polished to remove mill scale providing an excellent surface condition that minimizes surface area. Final cleaning of the chamber surface is done by electropolishing removing any trace residue from the manufacturing process thus leaving the vacuum surface with a chromium rich condition allowing for rapid pumpdown.

All 2-3/4 inch Del-Seal™ flanged ports are connected to the chamber with oversized 1-3/4 inch outside diameter tubing to provide maximum apertures and allow the installation of larger devices. All access ports are precision aligned with a helium-neon laser during construction.

HIGH VACUUM SERIES

We offer the following sizes as Standard

- 12" Sq x 18" Tall
- 24" Sq x 30" Tall

Standard Features

- 304L Stainless Steel body
- Electropolished surface finish
- Aluminum hinged door for easy access to interior
- Frame mounting feet

Standard Options

- Support Frame with leveling feet, p/n 220008
Frame options available
 - Swivel casters & leveling feet
 - Working surface & lower shelf
 - Instrumentation mounting rack
- Trace water-cooling
- Alternate sizes can be configured
- Alternate port sizes available

Port Specifications

- 12" Sq Box Chamber – Del-Seal™ Ports

2x	2.75"	Sides
2x	4.50"	Sides
2x	6.00"	Sides
1x	8.00"	Bottom
1x	4" Viewport	Door
- 24" Sq Box Chamber – Del-Seal™ Ports

2x	2.75"	Sides
2x	6.00"	Sides
2x	8.00"	Sides
1x	10.00"	Bottom
2x	4" Viewport	Door

Fastening and sealing hardware, including copper gaskets and bolt sets, are found under the individual size flange in the Flanges & Fittings section of the MDC catalog or on the website.

DESCRIPTION	WT LB	REFERENCE	PART NUMBER
12" SQ X 18" TALL BOX CHAMBER	207	CHAM-B-12	220003
24" SQ X 30" TALL BOX CHAMBER	930	CHAM-B-24	220004



12"x12"x18" Box Chamber

Front View

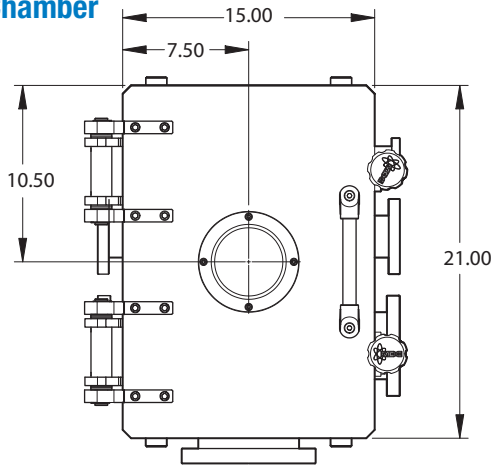

Side View

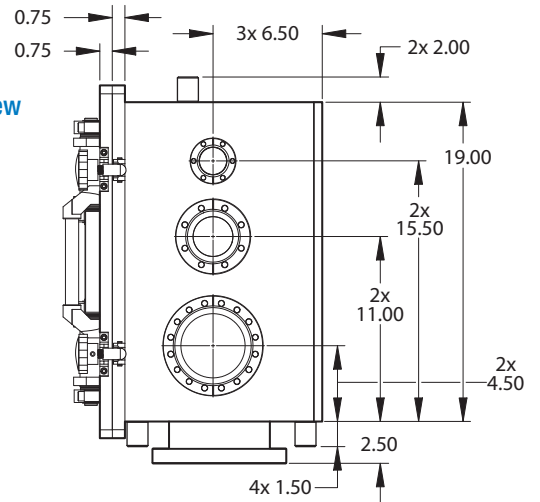

Bottom View

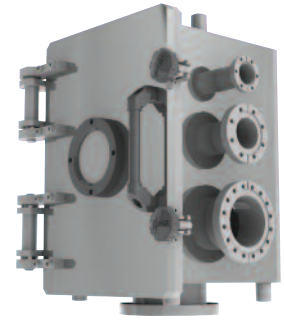
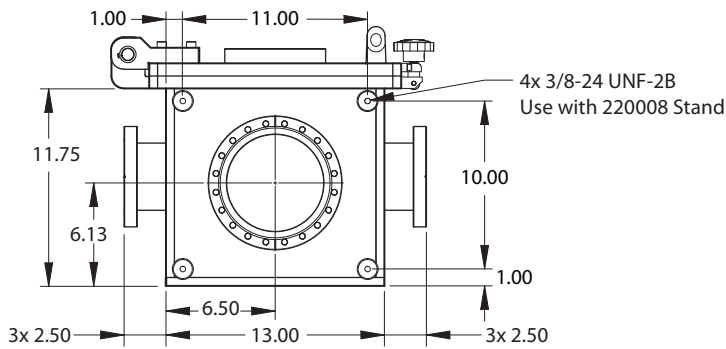

24"x24"x30" Box Chamber

Front View

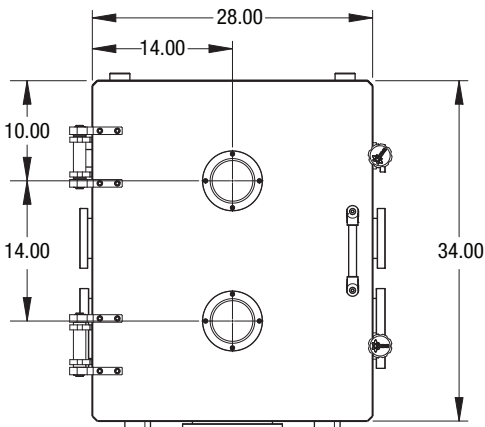

Side View

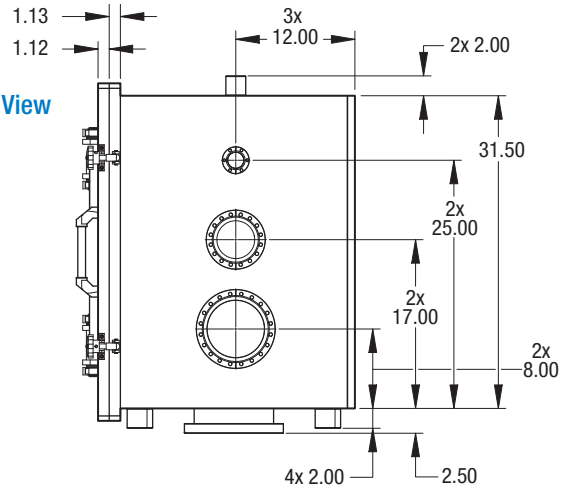

Bottom View

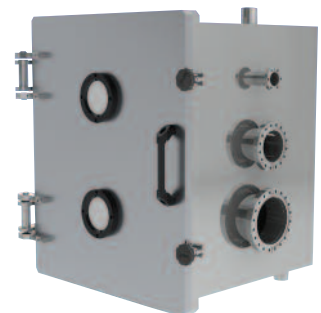
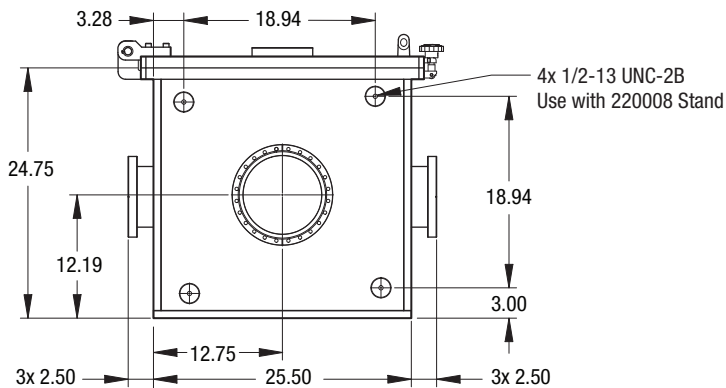

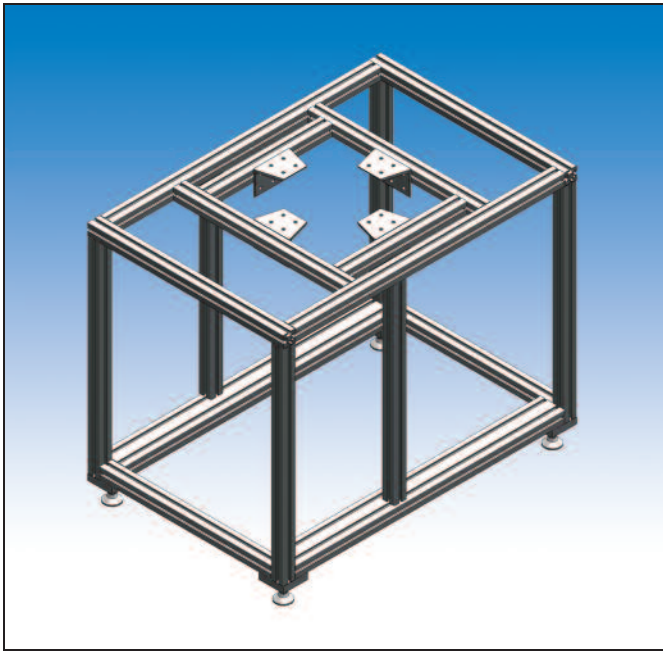

Standard Chamber Stand

Description

MDC Standard Chamber Support Frames are offered in two size configurations. These frames are versatile in design and can be used for our full range of Standard Chambers. The open frame allows access to all facets of a chamber and easy routing of instrumentation wiring.

For portability, optional swivel casters can be added to the frame. Once relocated, leveling feet provide a stable and stationary work environment. The upper and lower frames may be fitted with shelving to provide a work surface and an equipment dock. A standard 19-inch electronics rack may be added to house a complete system within a single frame.

ACCESSORIES

We offer the following sizes as Standard

- 24" x 36" tabletop size
- 36" x 36" tabletop size

Standard Features

- Open frame aluminum construction
- Adjustable leveling feet
- Frame 220002 used for both sizes of Standard Spherical Chambers
 - 12" Spherical, p/n 220000
 - 16" Spherical, p/n 220001
- Frame 220008 used for Standard D-Shape, Cylindrical and Box Chambers
 - D-Shape, p/n 220006
 - 24" Cylindrical, p/n 220005
 - 18" Cylindrical, p/n 220007
 - 24" Cylindrical, p/n 220005
 - 12" sq x 18" tall Box, p/n 220003
 - 24" sq x 30" tall Box, p/n 220004

Frame Options

- Swivel casters & leveling feet
- Working surface & lower shelf
- Instrumentation mounting rack

Frame Options

OPTION -01



OPTION -02

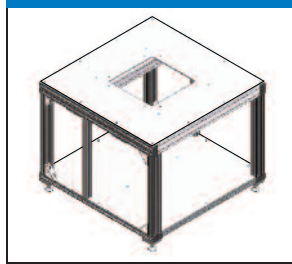

OPTION -03



DESCRIPTION	OPTION NUMBER
SWIVEL CASTERS & LEVELING FEET	-01
WORKING SURFACE & LOWER SHELF	-02
INSTRUMENTATION MOUNTING RACK	-03



24" x 36" Support Frame

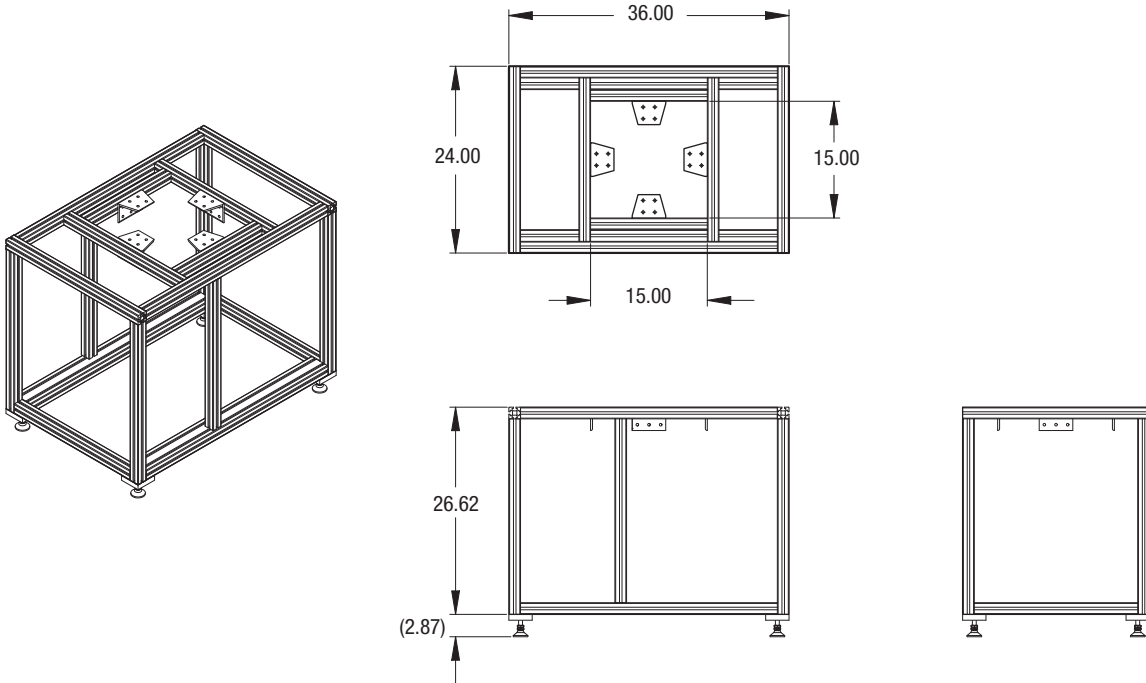

36" x 36" Support Frame

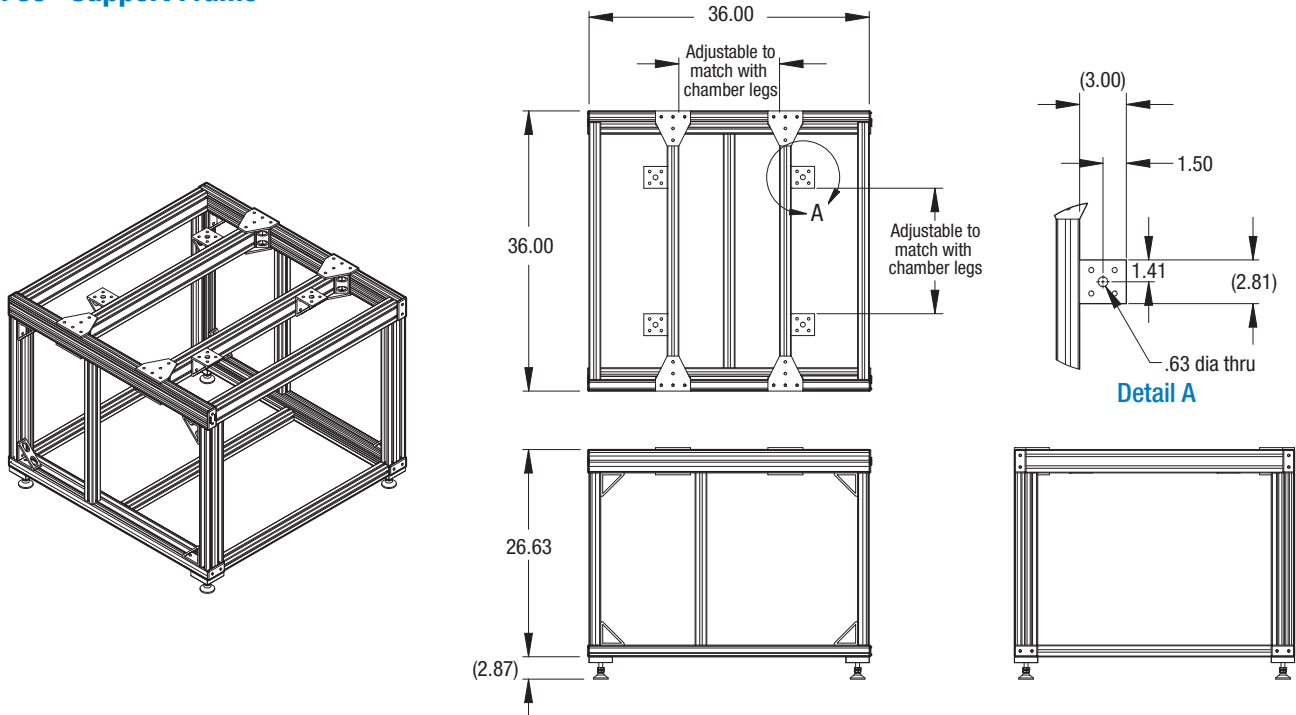

DESCRIPTION	WT LB	REFERENCE	PART NUMBER
24" X 36" SUPPORT FRAME	66	STAND-2436	220002
36" X 36" SUPPORT FRAME	105	STAND-3636	220008



Surface Science Analysis Chamber

Description

The SSAC-12 is a versatile, general purpose surface science analysis chamber. It has proven to be suitable for a wide range of studies and experiment. Standardization of the chamber design has enabled MDC to offer the SSAC-12 at this price.

The chamber has a total of 18 access ports. In addition to the pump port in the base, there are three 8", two 6", three 4-1/2" and nine 2-3/4" ports with Del-Seal™ CF metal seal flanges. The SSAC-12 has a 14-5/8" female wire seal flange on the pump port; the SSAC-12D is supplied with a 14" Del-Seal™ CF flange.

The chamber access ports accommodate a variety of experimental devices, analytical instruments, viewports, feedthroughs and other accessories. Note that the 2-3/4" flanges connect to the chamber with oversize 1.75" O.D. tubing to accommodate larger devices.

Access ports are precision aligned with a helium-neon laser during construction. Each is oriented toward one of three internal reference points A, B and C, or a vertical centerline. Angles and distances to these points are listed in the table.

Chamber construction is of type 304 stainless steel. All flange and tube connections are TIG fusion welds. All internal surfaces are electropolished to ultrahigh vacuum standards. Connection hardware, including copper gaskets and bolt sets, are found under the individual size flange in Section 1.1 of the MDC catalog.

Ports with colored flanges are unique to a single focal point. Ports to focal point A are shown in magenta; ports to focal point B are shown in purple; and ports to focal point C are shown in cyan. Ports which have more than one focal point or no listed focal point are shown without color. Focal length dimensions for ports with more than one focal point are given to the first focal point intersection.

ULTRAHIGH VACUUM SERIES

Features

- Proven design
- 18 Access Ports
- Del-Seal™ CF metal seal flanges
- Precision component alignment
- All type 304 stainless steel construction
- Bakeable to 450°C
- UHV compatible to 1×10^{-11} Torr

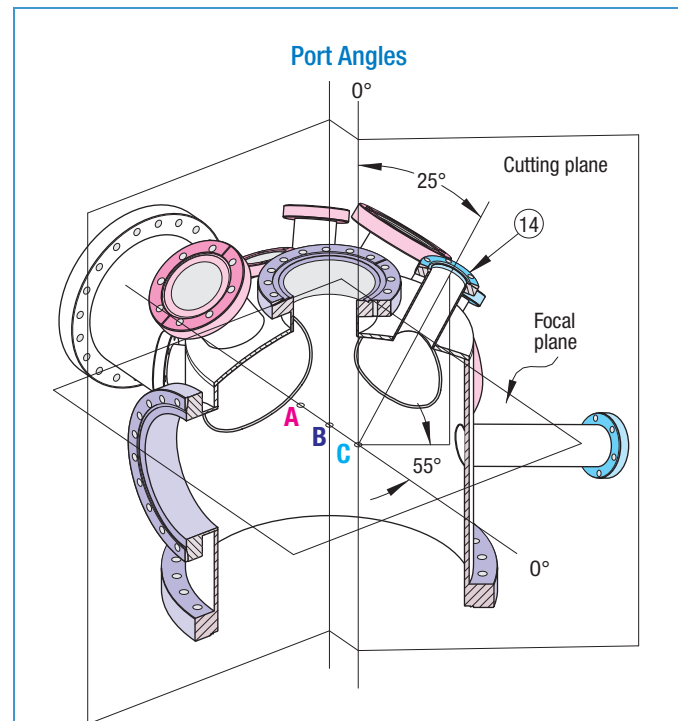

- The **polar angle** of a port is measured in a vertical plane that includes the focal point of the port and the centerline of the port
- The **azimuthal angle** of a port is measured as a projection of the port centerline onto a horizontal plane that includes the focal point of the port
- Example: Port 14 is aimed at focal point C
 - The cutting plane is vertical and passes through C
 - The cutting plane is rotated about a vertical line through C to include the centerline of Port 14
 - The **polar angle** of 25° is measured in the cutting plane
 - The **azimuthal angle** of 55° is measured in the focal plane



Top View

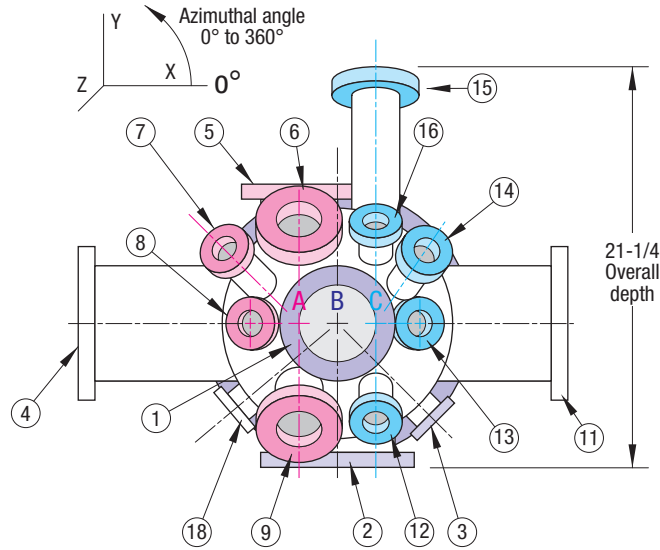

Side View

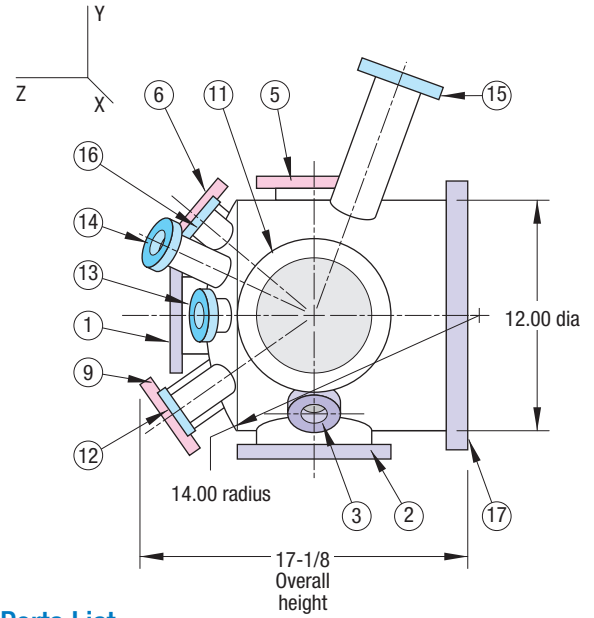

Front View

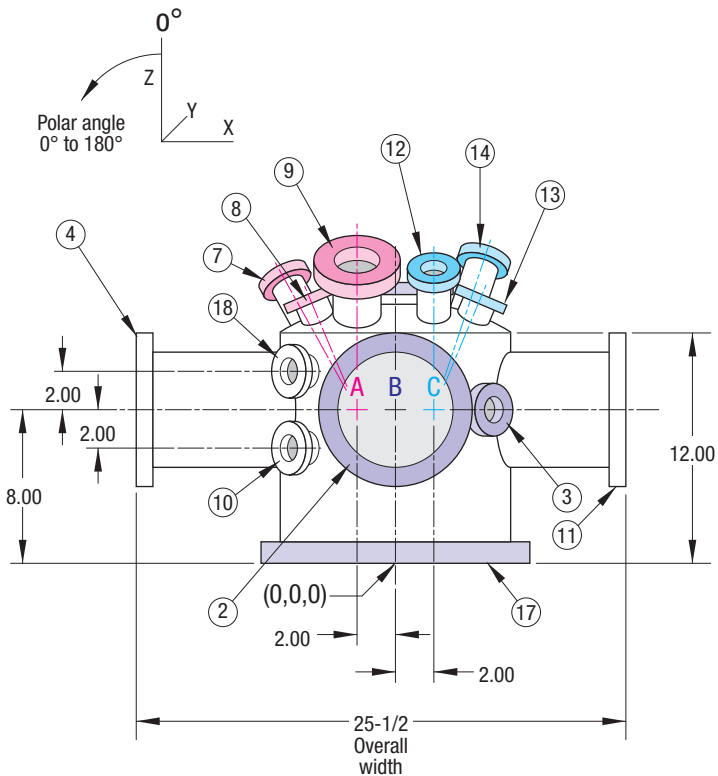

Ports List

PORT NO.	FLANGE SIZE	TUBE O.D.	FOCAL POINT	FOCAL LENGTH	AZIMUTHAL ANGLE	POLAR ANGLE
1	6	4.00	B	7.50	0	0
2	8	6.00	B	7.50	270	90
3	2-3/4	1.75	B	7.25	315	90
4	8	6.00	A	11.50	180	90
5	6	4.00	A	7.25	90	90
6	4-1/2	2.50	A	8.50	90	40
7	2-3/4	1.75	A	8.25	135	35
8	2-3/4	1.75	A	6.50	180	23
9	4-1/2	2.50	A	9.50	270	35
10	2-3/4	1.75	B1	7.25	220	90
11	8	6.00	C	10.00	0	90
12	2-3/4	1.75	C	9.00	270	35
13	2-3/4	1.75	C	6.50	0	23
14	2-3/4	1.75	C	9.00	55	25
15	4-1/2	2.50	C	13.75	90	110
16	2-3/4	1.75	C	7.75	90	40
17 ¹	14	12.00	B	8.00	0	180
18	2-3/4	1.75	B2	7.25	220	90

Focal Points (x,y,z)

A	-2.00, 0.00, 8.00	B1	0.00, 0.00, 6.00
B	0.00, 0.00, 8.00	B2	0.00, 0.00, 10.00
C	2.00, 0.00, 8.00		(Note: B1 & B2 not shown)

¹ Also available with 14-5/8" O.D. Female Wire Seal Flange.

DESCRIPTION	WT LB	REFERENCE	PART NUMBER
SURFACE SCIENCE ANALYSIS CHAMBER WITH 14-5/8" FEMALE WIRE SEAL FLANGE ON PORT 17	80	SSAC-12	200000
SURFACE SCIENCE ANALYSIS CHAMBER WITH 14" DEL-SEAL™ FLANGE ON PORT 17	80	SSAC-12D	200001



Typical stainless steel bell jar system

- Stainless steel bell jars
- Feedthrough collars
- Baseplates
- Base wells

Stainless Steel Bell Jars

MDC stainless steel bell jars are designed for use with MDC baseplates, base wells and feedthrough collars. A dovetail groove in the jar's base flange holds a Viton® elastomer gasket, which makes the vacuum seal with one of the forementioned components. All stainless steel bell jars are fitted with a four inch view diameter Pyrex® viewport. All vacuum welds are internal and provide UHV compatibility. For added convenience, all bell jars are fitted with a hoist or lift-ring that is welded to the chamber's domed top. These chambers can be purchased with an optional electropolished finish.

Feedthrough Collars

MDC feedthrough collars are used to expand the capabilities of conventional bell jars by providing radially oriented access ports. Four, eight, or eighteen ports fitted with either 2-3/4 inch Del-Seal™ CF metal seal flanges or ISO KF NW40 Kwik-Flange™ flanges are available. These ports accept a variety of standard MDC vacuum components such as electrical, fluid and motion feedthroughs. Installation of a feedthrough collar also requires the use of an MDC baseplate. The feedthrough collar is positioned between a bell jar and the baseplate. The feedthrough collar / baseplate seal is made with either an L-gasket or circular cross section elastomer, depending on which collar model is used. The feedthrough collar seal is made with an L-gasket elastomer. Stainless steel bell jars would use a circular cross section elastomer in the jar's dovetail groove to make this seal.

Baseplates

MDC base plates are required for installation of both bell jars and feedthrough collars. They provide a flat and stable platform upon which bell jar systems can be built. Baseplates are typically mounted atop a vacuum pump or the gate valve fitted to the pump. MDC offers three baseplate interface flanges for mating with standard pumps or gate valves. Interface flanges include ANSI ASA elastomer seal flanges, Del-Seal™ CF metal seal flanges and bolt style Large-Flange™ ISO LF elastomer seal flanges. Baseplates are available with baseplate flange diameters suitable for 12, 18 and 24 inch chamber body diameters.

Base Wells

Base wells are the product of integrating both a baseplate and a feedthrough collar. They provide the functionality of both components and replace one vacuum seal with a weld joint. They are available with radially oriented access ports in four, eight, or eighteen port configurations and are fitted with either 2-3/4 inch Del-Seal™ CF metal seal flanges or ISO KF NW40 Kwik-Flange™ flanges. These ports accept a variety of standard MDC vacuum components such as electrical, fluid and motion feedthroughs. Both baseplates and base wells connect to the vacuum pumping system with a choice of standard smooth face ASA ANSI flanges, optional Del-Seal™ CF metal seal flanges or ISO LF bolt-style Large-Flange™ flanges. Gasket seals for any flange or port are not included with baseplates or base wells and must be purchased separately. For pump port or access port flange hardware, refer to individual flange specifications in the Flanges & Fittings section of the MDC complete catalog or visit our website.

All dimensions in this catalog are given in inches unless specified otherwise.



Stainless steel bell jar page 18



Multi-port feedthrough collar page 20

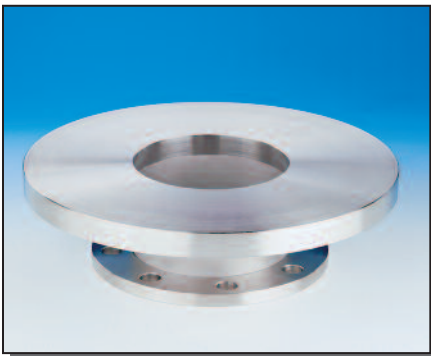

Baseplate page 22



Base well page 22

Typical bell jar chamber installation

Stainless steel bell jars are found on page 18

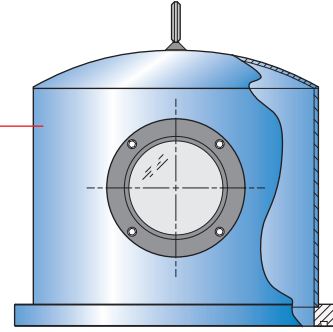

O-rings are on page 19



Multi-port feedthrough collars begin on page 20

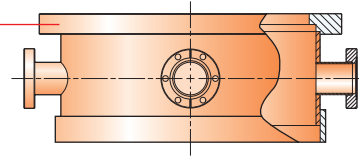

L-gaskets are on page 21



Baseplates and Base Wells are found on page 22

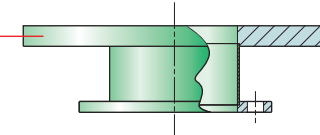

Gate valves are in Section 2.1 of the MDC catalog.

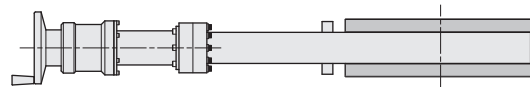

Cryogenic Sorption roughing pumps are in Section 3.2 of the MDC catalog — High vacuum pumps are customer supplied.

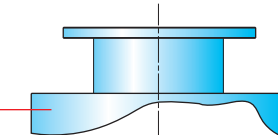

Typical configuration shown without connecting hardware for clarity



Stainless Steel Bell Jar

Description

Type 304 Stainless Steel Bell Jars are designed to be used with flat Baseplates, Base Wells and Feedthrough Collars. A dovetail groove in the jar's base flange holds a Viton® O-ring, supplied with each unit, which makes the vacuum seal with a baseplate. A PVP-4 Pyrex® Viewport with a four-inch diameter viewing area is included. All welds are internal. A single top-center lift ring is included. Electropolished finish option is available.

Specifications

Material	
Bell Jar	304ss
Gasket, elastomer	Viton®
Seal	
Gasket, elastomer	O-ring
Method	Gravity
Vacuum Range	1x10 ⁻⁶ Torr
Temperature Range	Ambient to 150°C
Weight & Dimensions	See table

HIGH VACUUM SERIES

Features

- 304ss material
- Viton® gasket seal
- Three standard sizes
- Pyrex® viewport PVP-4

Side view

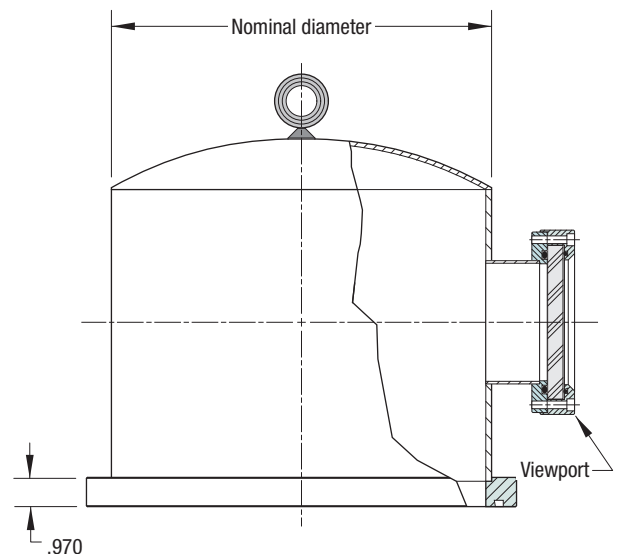

Front view

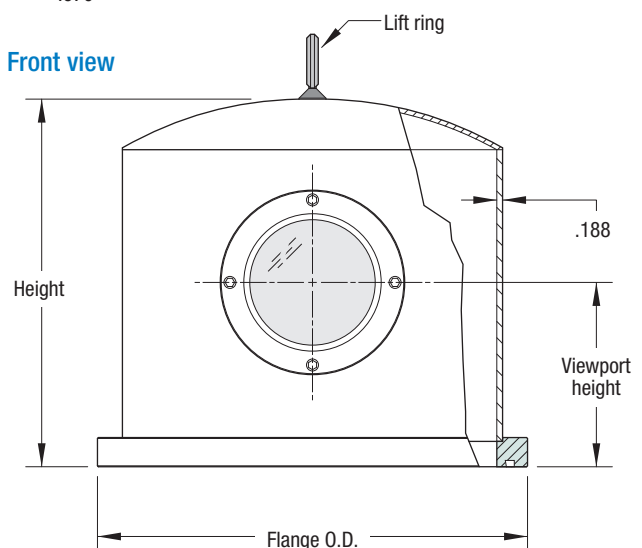



NOM. SIZE	I.D.	FLANGE O.D.	HEIGHT W/O RING	VIEWPORT HEIGHT	WT LB	REFERENCE	PART NUMBER
12	12.00	14.00	12.00	6.00	65	SSBJ-12	524000
18	18.00	20.00	30.00	12.00	195	SSBJ-18	524001
24	24.00	26.00	30.00	12.00	250	SSBJ-24	524002

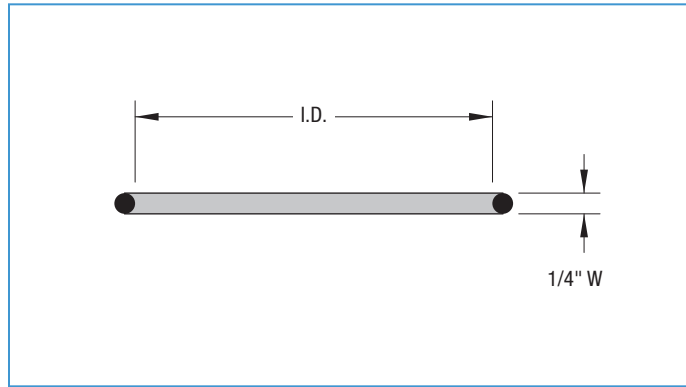
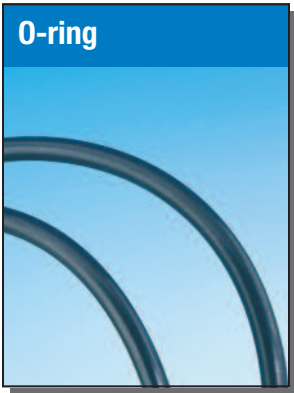

Use with Stainless Steel bell jar
 Viton® material
 Three standard sizes
 Also used with stainless steel Feedthrough Collars on page 20

NOMINAL SIZE	NOMINAL I.D.	WT LB	REFERENCE	PART NUMBER
10	12-1/2	1/8	OR-12	521003
12	18-1/2	1/8	OR-18	521004
18	25	1/8	OR-24	521005

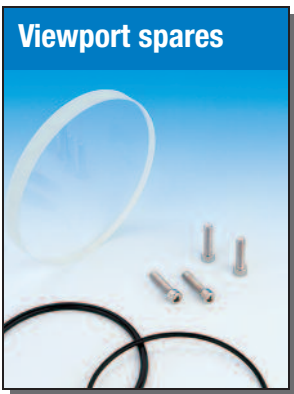

DESCRIPTION	WT LB	REFERENCE	PART NUMBER
REPLACEMENT GLASS, 7740 PYREX OPTICAL 5" O.D.	1	-	045010
BOLT, SOCKET HEAD, STAINLESS STEEL, .250-28 x 1" LONG (Pkg of 4)	1/4	-	190166
O-RING, GLASS-TO-FLANGE	1/4	-	041346
O-RING, GLASS-TO-RETAINER	1/4	-	041243

For viewport details, see the MDC catalog or visit our website.

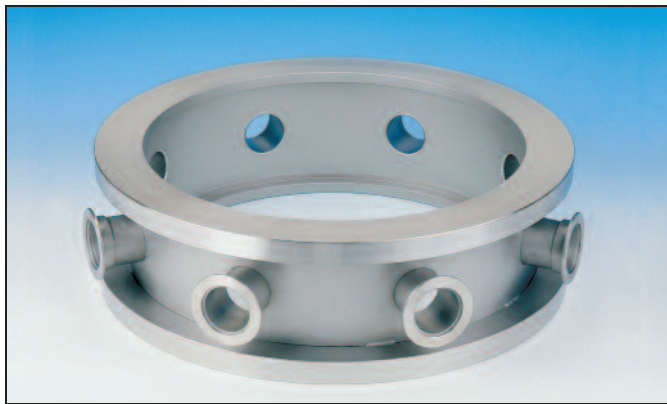

Feedthrough Collar, O-ring sealed



Feedthrough collar, L-gasket sealed

Features

- Choice of 2-3/4" Del-Seal™ CF flange or Kwik-Flange™ KF port connections.
- All type 304 stainless steel construction
- Elastomer seal on collar, one included

Description

Standard MDC Feedthrough Collars add four or eight convenient feedthrough ports to bell jar vacuum systems. These ports accept a variety of feedthrough devices and other components mounted on mating Del-Seal™ CF 2-3/4" flanges or ISO NW40 Kwik-Flange™ KF ports.

Installation of a feedthrough collar is made by positioning it between a bell jar and a baseplate. The lower collar-to-baseplate seal is made with either a Viton® L-gasket or O-ring, depending on which collar model is used. With Stainless Steel Bell Jars, a Viton® O-ring in the jar's dovetail groove makes the seal.

One O-ring or L-gasket is included with each collar. Dimensions and reordering information are found on the next page.

HIGH VACUUM SERIES

O-ring sealed

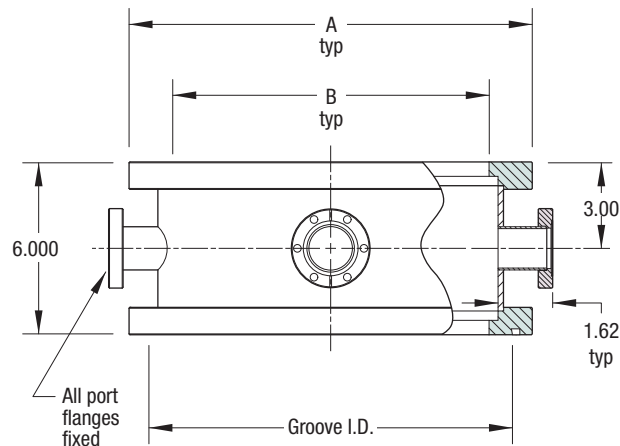

L-gasket sealed

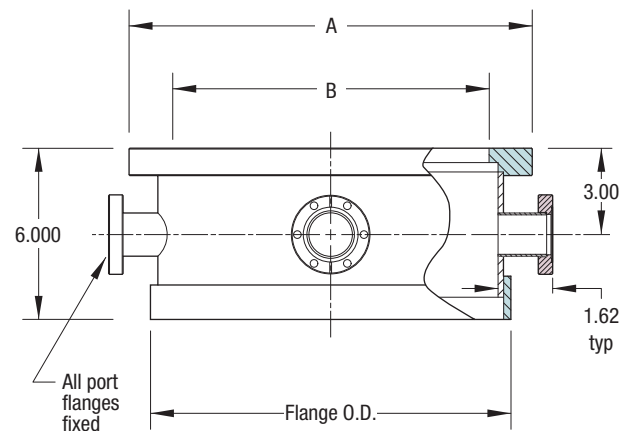

- Drawings show collars with four Del-Seal™ CF ports.
- All collar walls are nominally 3/16" thick.



O-ring sealed

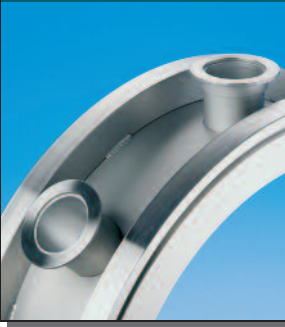

NOM. SIZE	NO. PORTS	PORT FLANGE O.D.	ISO REF.	A	B	O-RING GROOVE I.D.	WT LB	REFERENCE	PART NUMBER
DEL-SEAL™ CF PORTS									
12	4	2.73	-	14	11	12.50	65	FTCO-12	523002
18	8	2.73	-	20	16	18.50	150	FTCO-18	523003
24	8	2.73	-	26	23	25.00	230	FTCO-24	523004
KWIK-FLANGETM KF PORTS									
12	4	2.16	NW40	14	11	12.50	50	FTCO-K150-12	523022
18	8	2.16	NW40	20	16	18.50	85	FTCO-K150-18	523025
24	8	2.16	NW40	26	23	25.00	130	FTCO-K150-24	523028

L-gasket sealed



NOM. SIZE	NO. PORTS	PORT FLANGE O.D.	ISO REF.	A	B	FLANGE O.D.	WT LB	REFERENCE	PART NUMBER
DEL-SEAL™ CF PORTS									
12	4	2.73	-	14	11	12.5	35	FTC-12	523000
18	8	2.73	-	20	16	18.5	65	FTC-18	523001
KWIK-FLANGETM KF PORTS									
12	4	2.16	NW40	14	11	12.5	35	FTC-K150-12	523031
18	8	2.16	NW40	20	16	18.5	60	FTC-K150-18	523034

Seals

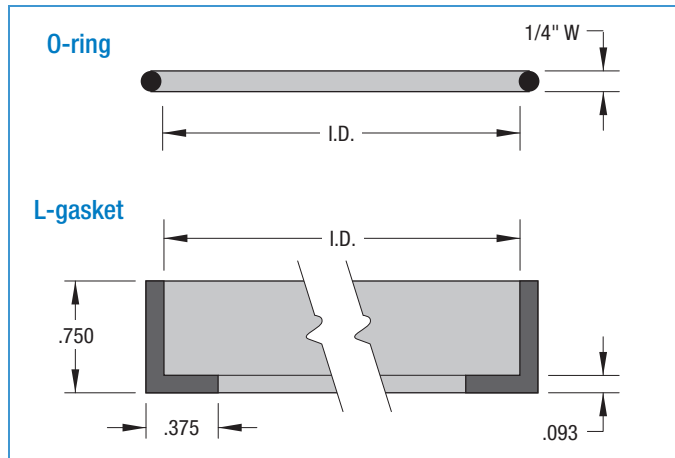

Viton® material

Three standard sizes for each type seal

NOMINAL SIZE	NOMINAL I.D.	WT LB	REFERENCE	PART NUMBER
O-RING				
10	12-1/2	1/8	OR-12	521003
12	18-1/2	1/8	OR-18	521004
18	25	1/8	OR-24	521005
L-GASKET				
10	9-1/4	1/4	GVL-10	521000
12	11-1/2	1/4	GVL-12	521001
18	17-1/4	1/4	GVL-18	521002

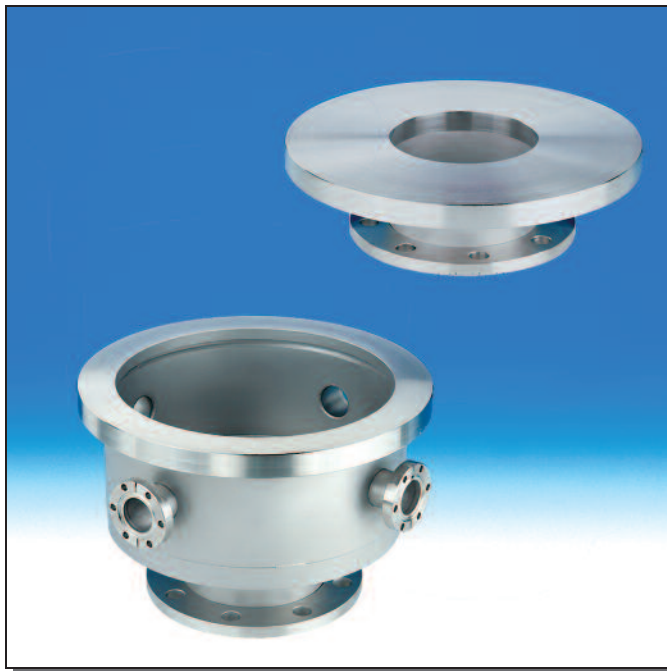

Baseplate and Base Well

Features

- 2-3/4" Del-Seal™ CF flange or Kwik-Flange™ KF NW 40 port connections on Base Wells
- Standard ASA pump port flange, with optional Del-Seal™ CF or ISO Large-Flange™ LF port
- All type 304 stainless steel construction
- Elastomer seal surface

Description

Installation of a Baseplate is made by positioning a Bell Jar or Feedthrough Collar directly on top of it. The bell jar-to-baseplate seal is made with either a Viton® L-gasket or O-ring, depending on which Bell Jar or Feedthrough model is used.

Standard MDC Base Wells are the integral combination of a Feedthrough Collar and a Baseplate, and eliminate one vacuum seal with a weld. Base Wells add four, eight, or eighteen convenient feedthrough ports to bell jar vacuum systems. These ports accept a variety of feedthrough devices and other components mounted on mating Del-Seal™ CF 2-3/4" flanges or Kwik-Flange™ KF NW40 sizes. If access ports are not required, Bell Jars can be mounted directly on Baseplates. Both Baseplates and Base Wells connect to the vacuum pumping system with a choice of standard smooth face ASA ANSI flange, or optional Del-Seal™ CF metal seal flange or Large-Flange™ LF bolt-style.

Seals for any flanges or ports are not included with Baseplates or Base Wells. For pump port flange or side port flanges, refer to individual flange specifications in Section 1 of the MDC catalog.

HIGH VACUUM SERIES

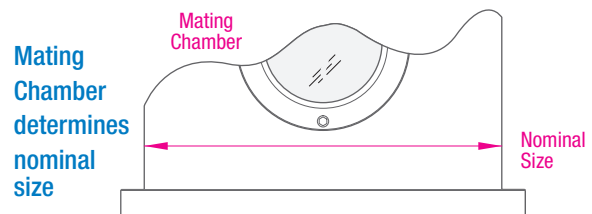

Baseplate

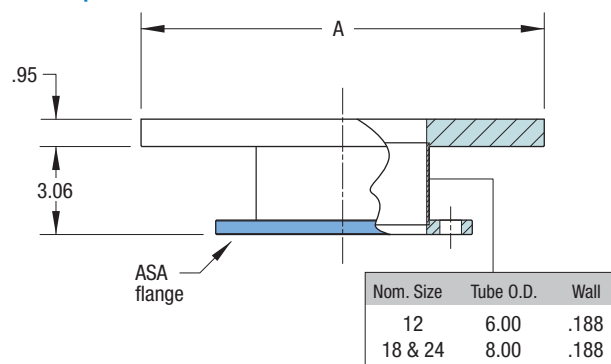

Base Well

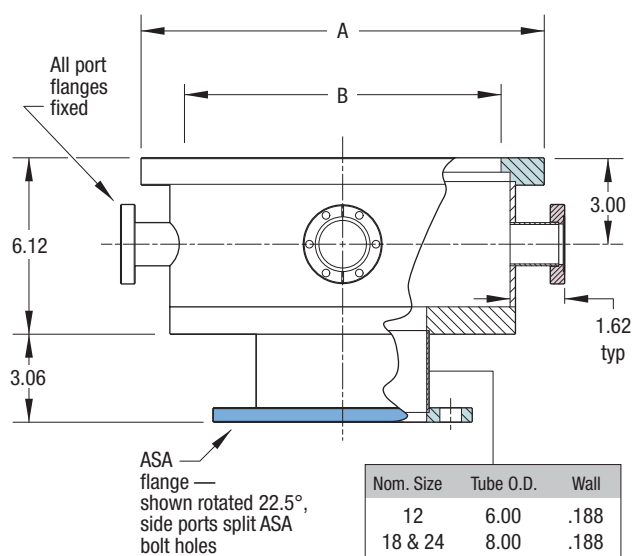

ASA Pump Port Flange

NOMINAL SIZE	ANSI REF.	ASA DIA.	ASA THK.	NO. HOLES	HOLE DIA.	BOLT CIRCLE
12	4	9.00	.50	8	.75	7.50
18 & 24	6	11.00	.75	8	.81	9.50

- ASA flanges are nonrotatable with a smooth face.
- O-ring grooves may be added as a special configuration.
- Base and port seals not included.



Baseplate

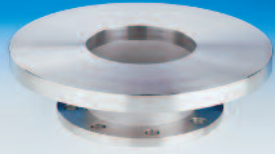

NOMINAL SIZE	PUMP PORT	ASA O.D.	A	WT LB	REFERENCE	PART NUMBER
12	ANSI-4	9.00	14	55	BP-12	523008
18	ANSI-6	11.00	20	110	BP-18	523009
24	ANSI-6	11.00	26	185	BP-24	523010

Base Well



NOMINAL SIZE	PUMP PORT	NO. PORTS	PORT FLG. O.D.	ISO REF.	A	B	WT LB	REFERENCE	PART NUMBER
DEL-SEAL™ CF SIDE PORTS									
12	ANSI-4	4	2.73	-	14	11	80	BW-12	523005
18	ANSI-6	8	2.73	-	20	16	160	BW-18	523006
24	ANSI-6	8	2.73	-	26	23	250	BW-24	523007
KWIK-FLANGETM™ KF SIDE PORTS									
12	ANSI-4	4	2.16	NW40	14	11	77	BW-K150-12	523050
18	ANSI-6	8	2.16	NW40	20	16	154	BW-K150-18	523053
24	ANSI-6	8	2.16	NW40	26	23	237	BW-K150-24	523056

Pump Port Options

Del-Seal™ CF



NOMINAL SIZE	MDC REF.	FLANGE DIA.	FLANGE THK.	NO. HOLES	HOLE DIA.	BOLT CIRCLE
12	F800600	7.97	.880	20	.332	7.128
18 & 24	F1000800	9.97	.970	24	.332	9.128

CHAMBER NOM. SIZE	OPTION NUMBER
12	-01
18 & 24	-03

Provides mating flange to metal-sealed port on vacuum pump. Optional elastomer seals available. See §1.1 of MDC catalog for flange specifications and sealing methods. Add option number to standard part number. Example: 523008-01

Large-Flange™ LF

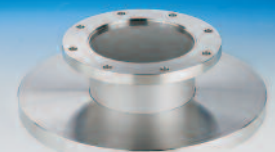

NOMINAL SIZE	ISO REF.	FLANGE DIA.	FLANGE THK.	NO. HOLES	HOLE DIA.	BOLT CIRCLE
12	NW160	8.86	.63	8	.43	7.87
18 & 24	NW200	11.22	.63	12	.43	10.24

CHAMBER NOM. SIZE	OPTION NUMBER
12	-02
18 & 24	-04

Provides mating flange to standard ISO port on vacuum pump. See §1.2 of MDC catalog for flange specifications and sealing methods. Add option number to standard part number. Example: 523008-02

Custom Engineering

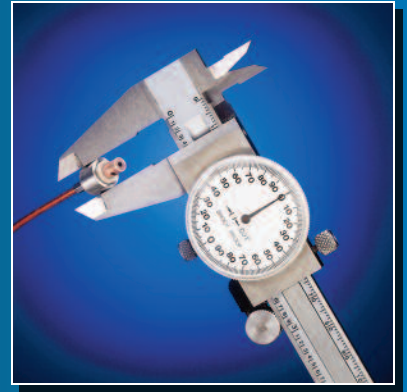

<u>Chamber Geometry</u>	26
<u>Modifications to Standard Parts</u>	28

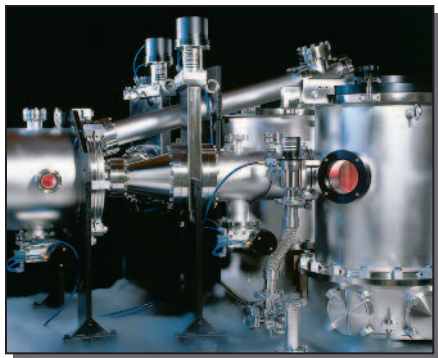

Typical MDC custom chamber

- Chamber geometry
- Focal point
- Focal plane
- Focal length
- Polar angle

Drawings provided for custom fabrication must include accurate, complete data. View angles and lengths do not provide complete information — true angles and port lengths must be specified for fabrication. Descriptions of focal length, polar and azimuthal angles are given on these pages.

MDC is equipped to build custom vacuum chambers of virtually any complexity. Vacuum vessels can be built to your exact specifications from a rough hand-sketch, detailed engineering drawings or anything in-between. MDC's engineering department uses the latest SolidWorks 3D CAD software and can accept drawings as electronic files in many file formats. For a nominal fee MDC can supply a complete engineering documentation package on those projects for which drawings were not provided by the customer.

Unless specified otherwise the main body of custom chambers less than or equal to 10 inches in diameter will be fabricated from standard tubing. Nonstandard sizes under 10 inches and all sizes over 10 inches in diameter shall be fabricated from rolled stainless steel sheet metal. The chart below provides nominal wall thicknesses for most MDC chambers .

The accurate positioning of ports on MDC vacuum chamber is made possible with the use of sophisticated laser aligned fixtures. Five basic geometric parameters are required to define a chamber's port positions. These spherical coordinate system parameters include a port's focal point, focal plane, focal length, polar angle and azimuthal angle, figures 3 through 6 on facing page.

For the purpose of this discussion all vacuum chambers shall have a base port located on a horizontal XY base plane which is perpendicular to the chamber's vertical Z axis, figure 3 on facing page. Whenever bolt style flanges are used, bolt patterns shall straddle vertical centerline. In the case of Del-Seal™ CF metal seal flanges fitted with leak test grooves, the grooves shall be oriented vertically, figure 1 below.

Furthermore, all port flange seal faces shall be considered perpendicular with their mating tube axes, figure 2 below.

The focal point of a port, also referred to as a ports target point, is usually a position anywhere inside a vacuum chamber where an application task is to be performed. Its location is typically defined by the vertex or convergence point of one or more ports and other chamber features. Focal points can be thought of as sphere centers from which radial ports project. Even though focal points are inside a vacuum chamber they are not necessarily at the chamber's center. Chambers can contain multiple focal points as required by an application. All focal points are located on focal planes which are parallel to the chamber's main base plane. A port's focal length is defined as an axial and perpendicular distance measured from a port's focal point to the center of its mounting flange seal face. Minimum focal lengths require the use of tapped flanges. Clearance hole flanges require a minimum 1-1/2 inch tube extension in order to fit fastening hardware.

Polar angle is a port's angular displacement about a horizontal axis. This horizontal axis of rotation intersects the port's focal point and lays on the focal plane which is in turn perpendicular to the chamber's main Z axis. Polar angles are measured in a north to south direction on a 180° scale between the focal point's vertical axis and the port's center line, figures 4, 5 and 6 on facing page. The north position is 0° and the south position is 180°. A port is said to have a 90° polar angle when the port centerline lays on the focal plane, figure 4.

Azimuthal angles discussed herein shall be measured in a counterclockwise direction with a 0° starting point and a full

Chamber Wall Thickness

Chamber Diameter	Wall Thickness
≤ 10.00	.120
> 10.00 but < 24.00	.188
≥ 24.00	.250

Please note that these wall thicknesses are given as reference only. Actual thicknesses may vary according to a chambers overall design including the size and quantity of ports being fitted. Contact MDC's technical sales engineers for more details.

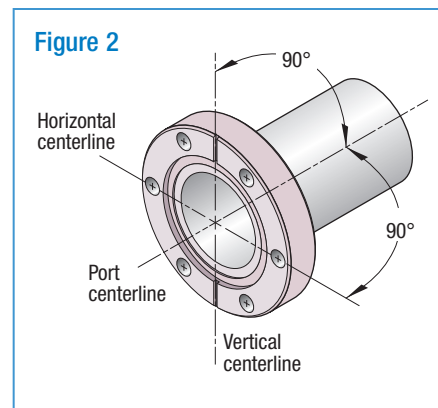
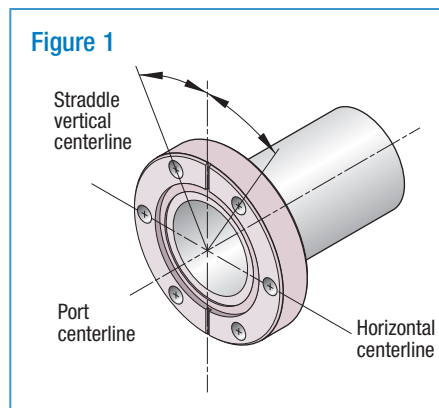



360° scale. Azimuthal angle is a port's angular displacement about a vertical axis. This vertical axis intersects the port's focal point and is always parallel to the chamber's main Z axis. The azimuthal angle is projected onto the port's horizontal focal plane and measured in a counterclockwise direction beginning at the 0° or three o'clock position and ending at the port center line or center line projection. If a port has a polar angle equal to 90°, figure 4, the port's center line will lay on the focal plane. If the polar angle is less than or greater than 90°, figures 5 and 6, the port's centerline will be above or below the focal plane and must be projected onto it for a final azimuthal angle measurement.

Custom engineered chambers are designed and manufactured using state of

the art metal machining equipment as well as conventional machining and welding tools. Unless specified otherwise the typical dimensional tolerances applied to all chamber fabrications shall be as follows...

Chamber fabrication tolerances have been optimized for cost-effectiveness and reproducibility. Chambers 24 inches in length or shorter will carry a ± 0.03 inch linear tolerance. Chambers longer than 24 inches but shorter than 72 inches will carry a ± 0.06 inch linear tolerance. All chambers will carry a minimum $\pm 1.0^\circ$ angular tolerance. Deviations from these specifications must be discussed with the MDC technical sales engineers for feasibility and cost before they can be implemented.

Figure 4

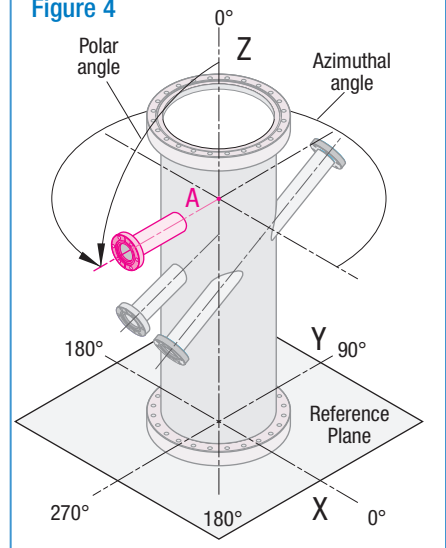

Figure 5

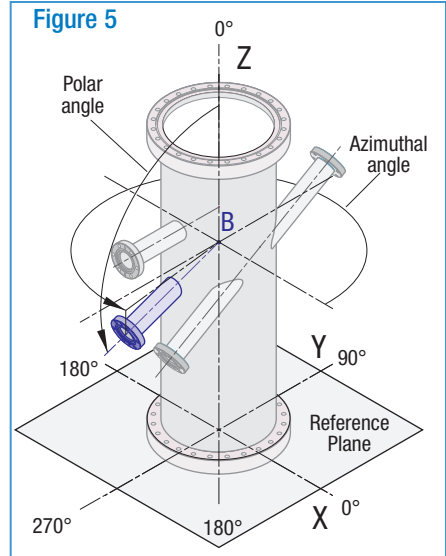

Figure 6

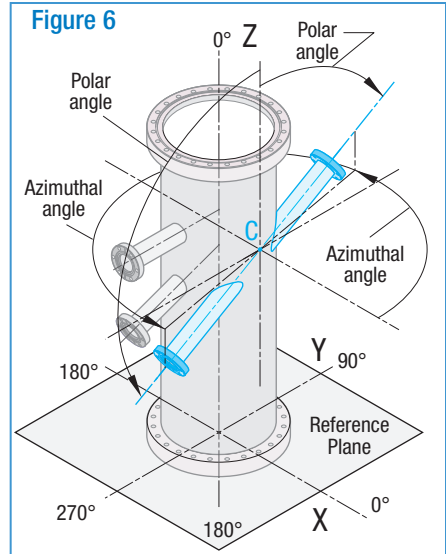
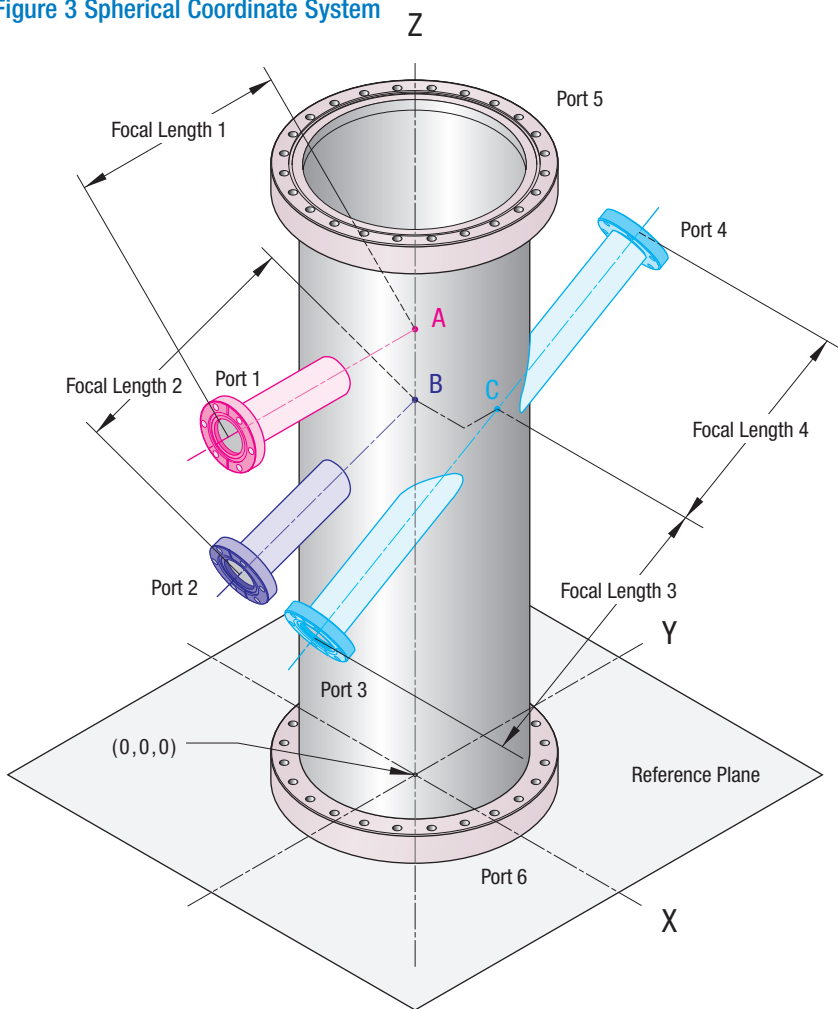
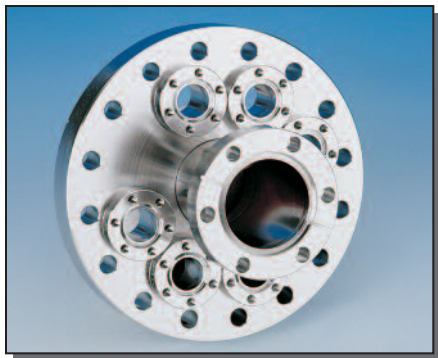

Figure 3 Spherical Coordinate System



General chamber nomenclature



Typical MDC custom multiport flange assembly. See the MDC catalog or visit our website for similar flanges.

MDC's technical sales engineers are available to discuss your requirements for any non-standard component. In the case where a catalog item may be close to your needs, but would benefit from a slight modification, the requirements could be easily noted using the existing catalog drawing. Locate the catalog page of the product to be modified. Provide the page number, a reference number if it's available, and a brief description of the modification requirements along with a marked up copy of the catalog drawing. Product specific drawings are available for most products depicted in this catalog and are usually presented with the table for those products.

MDC is equipped to build custom vacuum components of virtually any complexity. In the case where there is no standard component close to your needs, it will be necessary to generate a drawing. Custom components can be built to your exact specifications from a rough hand-sketch, detailed computer-generated engineering drawings or anything in-between. MDC uses SolidWorks 3D CAD software and can receive drawings electronically in many file formats. For a nominal fee MDC can supply a complete engineering documentation package on those projects for which drawings were not provided by the customer.

One example of the multiple ways to specify a custom component

The flange assembly at right depicts four popular methods of installing flanges in to a larger flange or plate. Del-Seal™ CF metal seal flanges have been used for the purpose of this example. The methods described would apply to most any flange type and configuration. The four methods of construction are referred to as standard tubulated, top flush mounted, zero length recessed and single piece integrally machined. These are given as examples for commonly asked questions. Discussing your application with an MDC technical sales engineer will help determine the appropriate solution for your application.

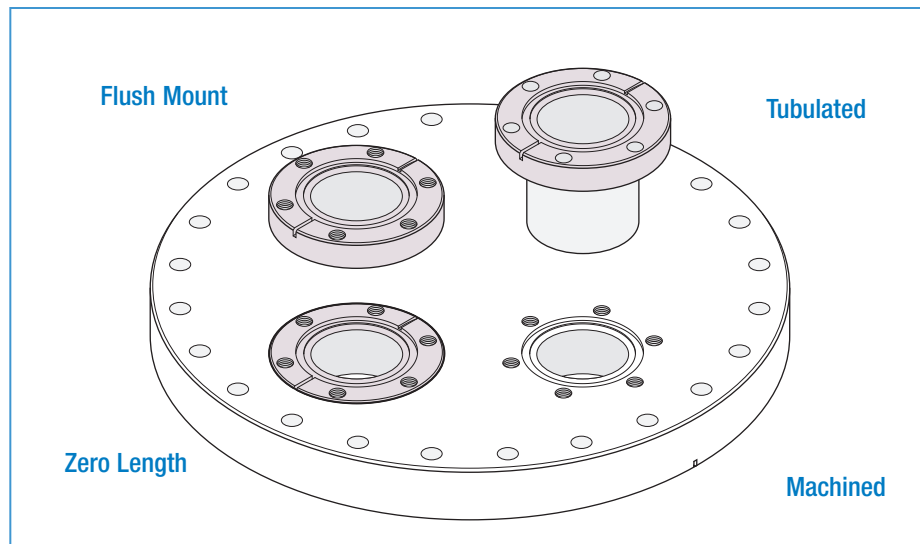

The tubulated method of construction would be one in which a standard or custom half-nipple is welded to the larger flange at the tube end. The larger flange or plate is counter-bored to match the tube's inside and outside diameters. The tube to flange transitions are welded in the same fashion along the bore's inside diameter. This method of construction allows the use of clearance hole, bolt and nut fasteners, and is the only configuration that would allow the use of a rotatable flange.

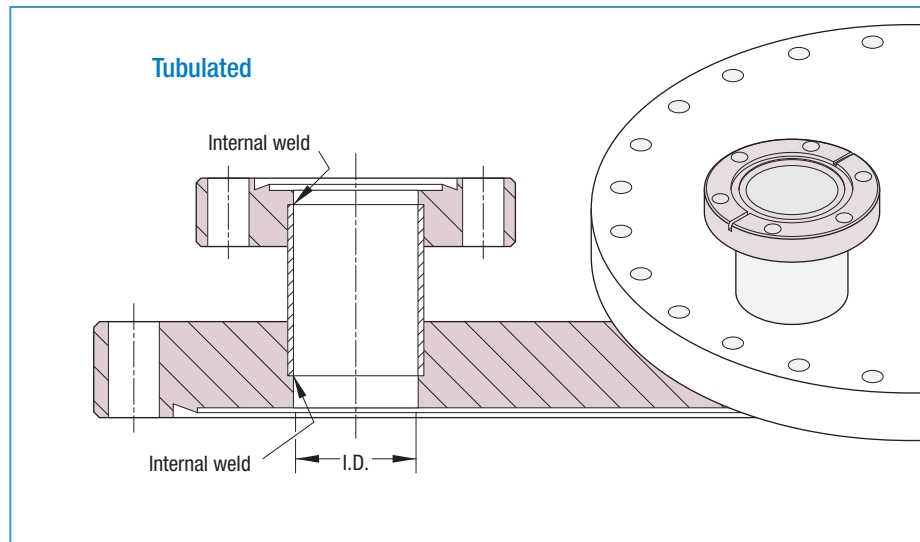



The most economical method of installing a flange would be to use standard off the shelf components requiring the minimum amount of modification and fabrication or in other words a top mounted method. In this method the larger flange or plate is bored to match the bore size of a smaller flange. Both are then joined by fusion welding internally along the interface between the two bored pieces. In some cases, external skip welds are provided for additional mechanical strength. This is the most economical method of construction.

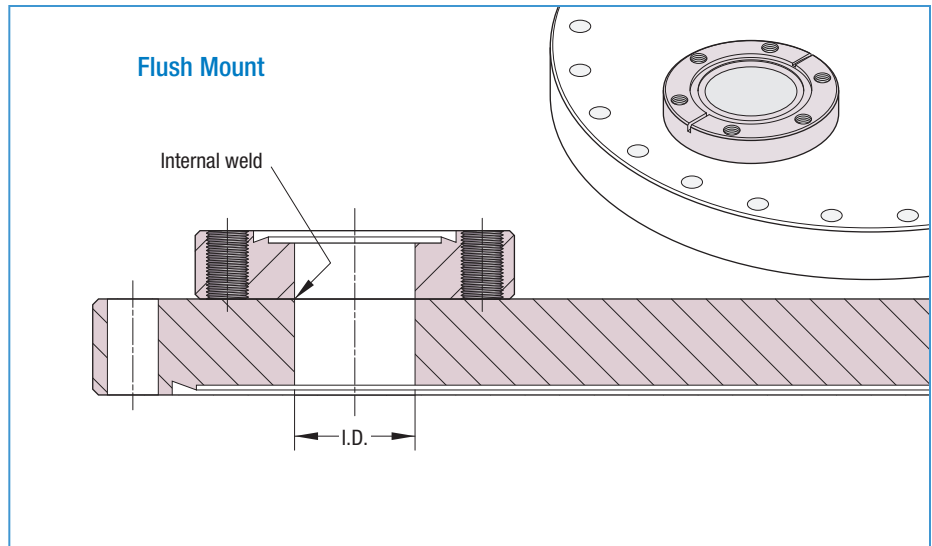

The zero length method of installation is similar to the top mount method with one exception, the larger flange or plate is counter-bored to a depth that matches the thickness of the smaller flange. The counter-bore is used to reduce the overall thickness of the completed assembly and thus provides a zero length recessed profile. The flanges are welded in the same fashion along the bore inside diameter. This approach provides a more aesthetic look at a reasonable cost.

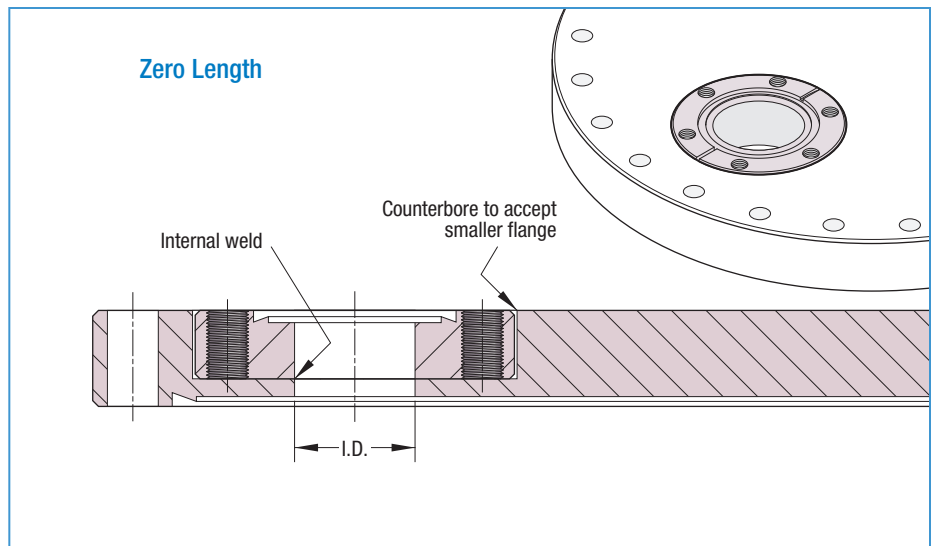

An integrally machined method eliminates all weld joints, but requires the most amount of machining. Special machining steps include the use of blind-tapping for all bolt holes and off-center turning of the knife-edge seal geometry as well as through bore operations. In some instances it may even be desirable to use helical thread inserts, since these would be easy to replace in the event a thread is damaged. Conventional threads would be very difficult to repair. This type of fabrication is the most aesthetic, but also the most expensive of the three choices.

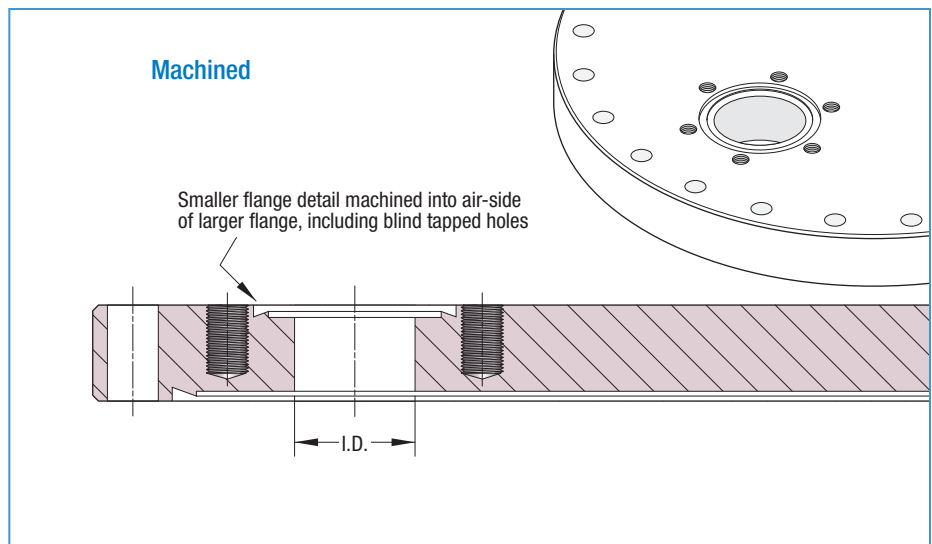



Visit mdcvacuum.com to order online and for all of the latest pricing, new product and sales representative contact information.

Access over 5,000 parts online – Thousands of components in-stock and ready to ship today!

WWW.MDCVACUUM.COM

Our entire product line is featured online, with most updated pricing and inventory. Register and you will have access to ordering online as well as documents from our FAQ and technical library archives.

Contact US

We have a highly trained sales and support staff who are knowledgeable about our products and willing and able to help you make an informed buying decision, and even assist you after the sale.

Sales

Phone: 800 443-8817
 Fax: 510 887-0626
 e-mail: sales@mdcvacuum.com

Chambers

MDC = Call MDC Direct (800-443-8817)

Canada
 Intlvac
 905-873-0166
sales@intlvac.com

MDC Direct
 Semi Account Manager
 Mary Osborne
 510-209-2331
MOsborne@mdcvacuum.com

MDC Direct
 MDC only - SF-East Bay
 Rose Kaslin
 800-443-8817
websales@mdcvacuum.com

Power Connection
 Val Robinson
 408-779-8888
vrobins@powerconnectioninc.com

Vacuum One
 Scott Dix
 773-244-3102
information@vacuumone.com

PTL Vacuum
 Bill Branagan
 315-776-5040
sales@ptlvacuum.com

Torvac
 Steve Borden
 763-544-0888
sales@torvac.com

Stavac
 Dave Stapleton
 724-586-2100
dave@stavac.com

Hartech Corporation
 Steve Harvell
 781-863-1448
hartech1@ix.netcom.com

Power Connection
 Northern CA from Oregon border south to and including Ventura Co. -ISI
 Northern SF Bay to Oregon Border and south to and including San Luis Obispo-MDC
 Val Robinson
 408-779-8888
vrobins@powerconnectioninc.com

Telesis High Vacuum
 Rob Armstrong
 972-726-6960
rob@telesishivac.com

MDC Direct
 Rick Appel
 303-249-0327
rappel@mdcvacuum.com

Eastern Vacuum
 Rich Glazewski
 215-822-6398
EasternVacuum@Verizon.net

AVTEC
 So. CA for MDC and ISI;
 Ventura Co. MDC only
 Clyde Madsen
 949-499-6600
clyde@teamAVTEC.com

Scientific Sale & Support, Inc.
 Mike Rider
 505-345-9680
m1053ride@yahoo.com

Enviro-Vac Systems
 James Johnson
 865-212-3626
jjohnson@enviro-vacsystems.com

Triangle Vacuum
 Brian McGlynn
 919-362-3790
trianglevacuum@gmail.com

Effective 9/4/09



Shipping Method

All standard shipments are made by the following method unless otherwise specified:

- FOB Hayward, California;
- prepay and added to invoice (PPA);
- shipped via UPS ground service or best way as determined by MDC.

Nonstandard shipments must be specified by the customer. General notes include the following:

- orders may be specified to ship collect;
- charges for nonstandard methods of shipping are determined by the specified carrier;
- in some cases, oversized items may be charged at a “dimensional weight” (dimensional weight) rate which is substantially higher than surface rates.

MDC recommends in all cases that an alternative carrier be named at the time of order.

Weights stated in this catalog are for reference only. Exact shipping weights are determined at the time of shipment.

Payment Terms

Net 30 days with prior credit approval. VISA®, MasterCard® and American Express® credit cards, prepaid, are also accepted.

Prices and Specifications

Prices and specifications are subject to change without notice.

Delivery

Every effort will be made to ship within three (3) days of receipt of an order. In the event of back-order, a firm delivery date will be established and quoted.

Warranty

All products manufactured by MDC Vacuum Products, LLC are warranted to be free from defects in materials and workmanship for a period of twelve (12) months from the date of shipment by MDC Vacuum Products, LLC to the buyer. Liability under this warranty is expressly limited to repair or replacement of defective products at the option of MDC Vacuum Products, LLC. Products returned to MDC Vacuum Products, LLC for repair or replacement shall be received prepaid. Expendable items such as gaskets, bellows, bearings, lubricants, *etc.*, may have a service life of less than one year in normal usage. If such items fail to give reasonable service for a period of time, as determined by MDC Vacuum Products, LLC, they will be repaired or replaced by MDC Vacuum Products, LLC at its election.

Return Policy

In the event that a product is to be returned to MDC, a Return Authorization (RA) number must be obtained from the MDC Sales Department prior to shipment of the product. Call the toll free number listed at the bottom of this page and request an RA number. To facilitate processing, please provide the original date of purchase and either the original purchase order number or the original MDC sales order number.

Products returned to MDC Vacuum Products, LLC for repair or replacement shall be received prepaid. Items arriving without a Return Authorization number will be refused.

A product failing to give reasonable service for a period of time, as determined by MDC Vacuum Products, LLC, will be repaired or replaced by MDC Vacuum Products, LLC at its election.



23842 Cabot Boulevard
Hayward, CA 94545-1661

Phone 510.265.3500

Toll-Free 800.443.8817

Fax 510.887.0626

Email sales@mdcvacuum.com

Web www.mdcvacuum.com