

Section 3



Roughing components

3.1 Foreline traps	182	3.3 Roughing components	198
Foreline traps introduction	182-183	Up to air valves	198
Molecular sieve	184-185	Special flanges	199
Coaxial	186-187	Burst discs	200
Coaxial with replacement filter	188-189	Lubricants	201
Filter elements	190-191	Vacuum sealants and glues	202
Liquid nitrogen	192-193	UHV and bakeout accessories	203-206
3.2 Vacuum pumps	194	TSP Tee and insert	203
Cryogenic sorption	194-197	Flexible bakeout tents	204
		Bakeout fan unit and controllers	205
		Bakeout cables	206



Foreline traps

Introduction



The Caburn-MDC family of roughing line traps

Features

- Molecular sieve trap
- Single-piece coaxial trap
- Two-piece coaxial trap
- Liquid nitrogen trap

Molecular sieve traps

Molecular sieve traps containing type 13X synthetic zeolite effectively prevent oil backstreaming and trap water vapours at room temperature. Type 13X zeolite will absorb molecules with critical diameters up to 10 angstrom. The sieve charge can be reactivated by baking out in place when a base vacuum cannot be achieved. A valve should be used to isolate the evolved gas from the system during the bakeout cycle. During bakeout a mechanical pump removes the evolved gases from the sieve trapping material. To minimize downtime, bakeouts can be conducted with the aid of a timer, during system offhours. Oils trapped by the sieve material will not be evolved by baking. Periodic replacement of the sieve material is required whenever the sieve material exhibits evidence of hydrocarbon saturation as determined by empirical observation. The sieve trapping material is easily replaced through a port fitted to the top of the trap.

Molecular sieve traps can be mounted in a vertical or horizontal position. Once turned on, the heater reaches and maintains a self-regulated and constant 150°C temperature. Bakeout time depends on the amount of water vapour loading of the zeolite and can range from four to twelve hours.

Coaxial traps

Coaxial foreline traps offer easy maintenance and room-temperature operation, they require no bakeout or cooling and are virtually maintenance free. They are ideally suited for trapping roughing pump hydrocarbons from backstreaming into a vacuum system. Single-piece coaxial foreline traps contain absorbent filter cartridges with a bronze wool element. This filter element is permanently sealed inside the trap's body and can't be removed or replaced. These traps are serviced by replacing them with a spare unit while cleaning the contaminated trap. Single-piece traps are available in 100mm and 150mm body diameters.

In contrast to the single-piece units, the two-piece coaxial foreline traps offer a wider selection of filter element materials. Filter elements for a two-piece trap are removable, stainless steel screen cartridges filled with copper, stainless steel or bronze wools, activated alumina, activated carbon or dual-element absorbent materials.

During operation, pump oil coalesces on the element and returns to the pump. Activated alumina effectively adsorbs acids and water vapour while activated carbon adsorbs organics and water vapour. Filter cartridges are

quickly and easily replaced by removing the banded clamp that fastens the two-piece body.

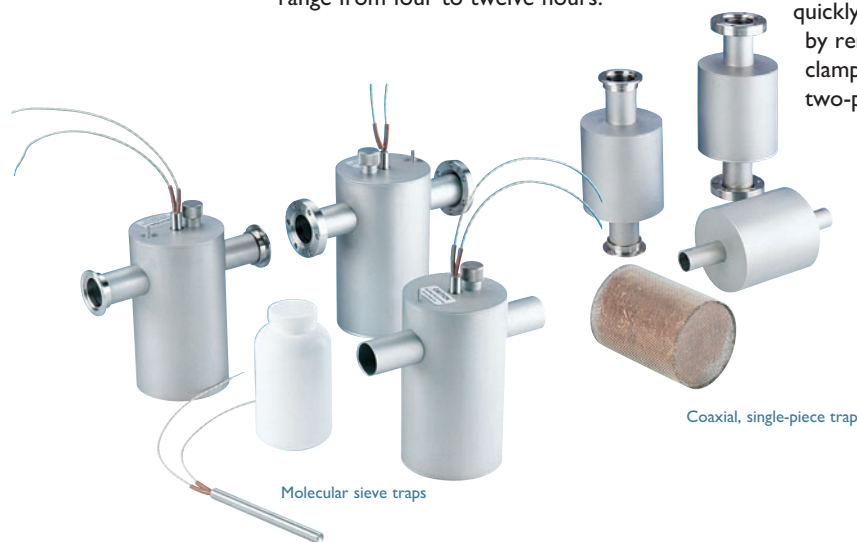

Molecular sieve traps

Coaxial, single-piece traps

All dimensions are nominal in millimetres unless specified

Caburn-MDC Europe Limited Telephone +44 (0)870 428 7646 www.caburn.co.uk





Caburn-MDC recommends keeping a spare element onhand for a quick change to minimize down time. Reusable elements may be cleaned and ready for the next exchange.

Note that filter elements are not included with trap assemblies and must be ordered separately.

Two-piece traps are offered with 50, 100, 150 and 200mm body diameters. All coaxial trap bodies are made of type 304 stainless steel and are offered with a choice of hose or flange style connections. CF metal seal flange connections have one fixed and one rotatable flange for alignment purposes. ISO KF and ISO LF flanges are clamp-style. Hose connections may also be welded, but permanent installation must be carefully evaluated.

Liquid nitrogen traps

Liquid nitrogen traps remove condensables before they enter the pump or backstream from the pump to the vacuum system. Water trapping by the liquid nitrogen cooled surface is complete and permanent.

Liquid nitrogen traps can be fitted with a customer-supplied coolant level controller to automatically replenish consumed liquid nitrogen.

In general, trap performance will vary with the specific application, usage, number of process cycles and relative humidity in the region. One cycle per day in an R&D application could provide approximately six months of maintenance free service. Production type applications will require more stringent preventative maintenance programs tailored to a specific application.

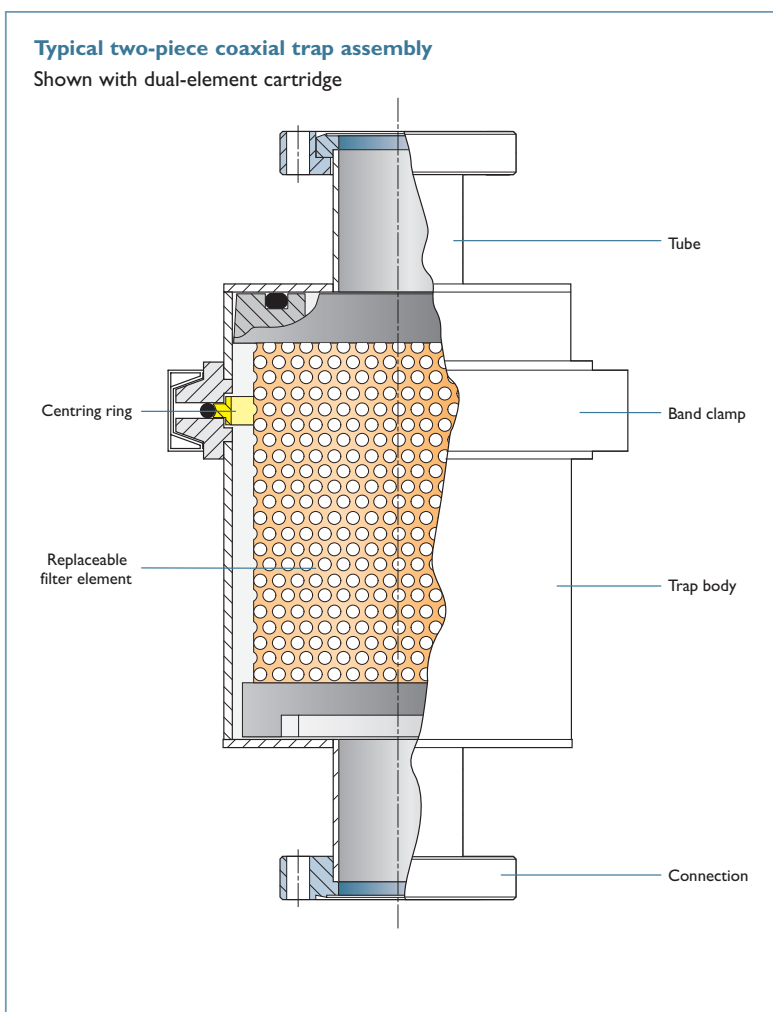

Liquid nitrogen traps

Coaxial, two-piece traps

All dimensions are nominal in millimetres unless specified

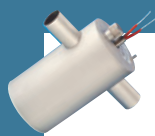

Foreline traps

Molecular sieve



Features

- Effectively blocks backstreaming by absorbing hydrocarbons
- Traps water vapour
- Regeneration using built-in heater
- 304 stainless steel trap body
- Available in four sizes

Description

Molecular sieve traps containing type 13X synthetic zeolite effectively prevent oil backstreaming at room temperature. They also trap water vapour in the sieve charge. The sieve charge can be reactivated by baking out in place when the base vacuum cannot be achieved. A valve should be used to isolate evolved gas from the system during bakeout cycle. During bakeout the mechanical pump removes the evolved gas from the sieve trapping material. Normal bakeout can be accomplished by use of a timer during system off hours.

Any oils trapped by the sieve material cannot be removed by baking. Periodic replacement is required whenever the sieve material exhibits evidence of hydrocarbon loading as determined by empirical observation. Sieve trapping material can be replaced through port on top of trap. Traps can be mounted in the standard vertical or horizontal position.

The heater reaches and maintains a self-regulated constant 150°C temperature. Bakeout time depends on the amount of water vapour loading of the zeolite, within the range of four to 12 hours.

UHV and HV series

CF Ports

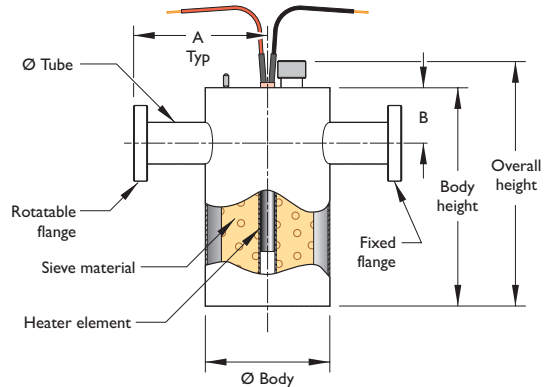

ISO KF and LF ports

KF 19.1 to 50.8 tube diameter

LF 76.2 tube diameter

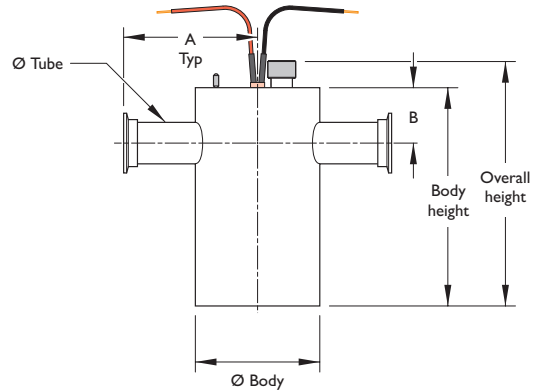

Hose connection

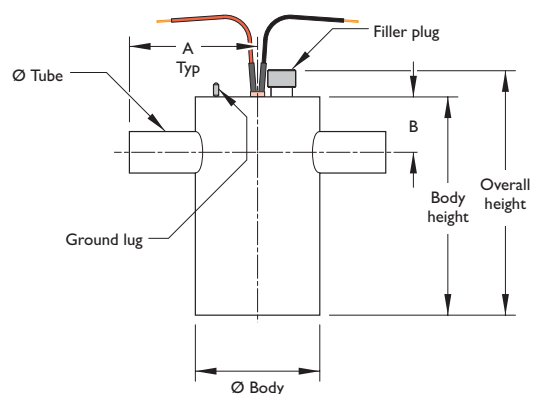

All dimensions are nominal in millimetres unless specified. Weights given are approximate.



CF



Trap size	Flange	Tube dia.	Body dia.	Body height	Overall height	A	B	Wt kg	Reference	Part number
100	DN16CF	19.1	114	133	162	127	43	1.8	E-MST-075-2	431035
100	DN40CF	38.1	114	200	229	119	51	2.5	E-MST-150-2	431040

ISO KF



Trap size	Flange	Tube dia.	Body dia.	Body height	Overall height	A	B	Wt kg	Reference	Part number
100	DN16KF	19.1	114	133	162	127	43	1.8	E-KMST-075-2	431036
100	DN25KF	25.4	114	133	162	118	43	2.3	E-KMST-100-2	431038
100	DN40KF	38.1	114	200	229	119	51	2.5	E-KMST-150-2	431041
100	DN50KF	50.8	114	200	229	119	51	2.7	E-KMST-200-2	431045

Hose connection

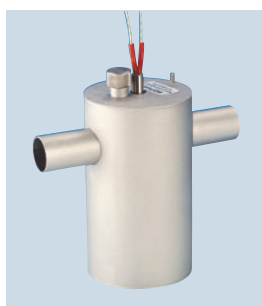

Trap size	Body dia.	Body height	Overall height	A	B	Wt kg	Reference	Part number
100	114	133	162	114	43	1.8	E-MST-075	431034
100	114	133	162	114	43	2.3	E-MST-100	431037
100	114	200	229	114	51	2.5	E-MST-150	431039
100	114	200	229	114	51	2.7	E-MST-200	431044

Accessories



Description	Wt kg	Reference	Part number
Molecular sieve replacement charge, type 13x, 0.5-0.2 kg	0.7	MST-C	431013
Replacement heater assembly, 220-240V AC	0.1	E-MST-H	431046

Mechanical pump size	Recommended trap tube size	Gas handling load (50% relative humidity)	Capacity gm	Trap reference number	Number charges required
Up to 15 m ³ /hr	19 & 25	1.7m ³	500	E-MST-075 & -100	1
15 to 27 m ³ /hr	38	3.5m ³	726	E-MST-150	2
27 to 51 m ³ /hr	50	3.5m ³	726	E-MST-200	2

All dimensions are nominal in millimetres unless specified Weights given are approximate

Foreline traps

Coaxial



Features

- Significantly reduces oil backstreaming
- Low cost one-piece body design
- Bronze wool element
- 304 stainless steel trap body
- 100mm and 150mm body diameters

Description

Coaxial foreline traps offer easy maintenance and room temperature operation, they require no bakeout or cooling and are virtually maintenance-free. They are ideally suited for trapping roughing pump hydrocarbons and preventing them from backstreaming into a vacuum system. Single-piece coaxial foreline traps contain absorbent filter cartridges filled with a bronze wool element. This filter element is permanently sealed inside the trap's body and can't be removed or replaced. These traps are serviced by replacing them with a spare unit while cleaning the contaminated trap. Single-piece traps are available in 100mm and 150mm body diameters.

Trap bodies are manufactured from type 304 stainless steel. Traps are offered with a choice of hose or flange connections. CF metal seal flange connections have one fixed and one rotatable flange for alignment purposes. KF and LF ISO flanges are clamp-style.

Hose connections may also be welded, but permanent installation is not recommended. Used traps may be cleaned with a solvent and allowed to dry before replacing into service. Caburn-MDC recommends having a spare trap available for rapid replacement to minimize down time. The used unit may be cleaned and stored for re-use as convenient.

UHV and HV series

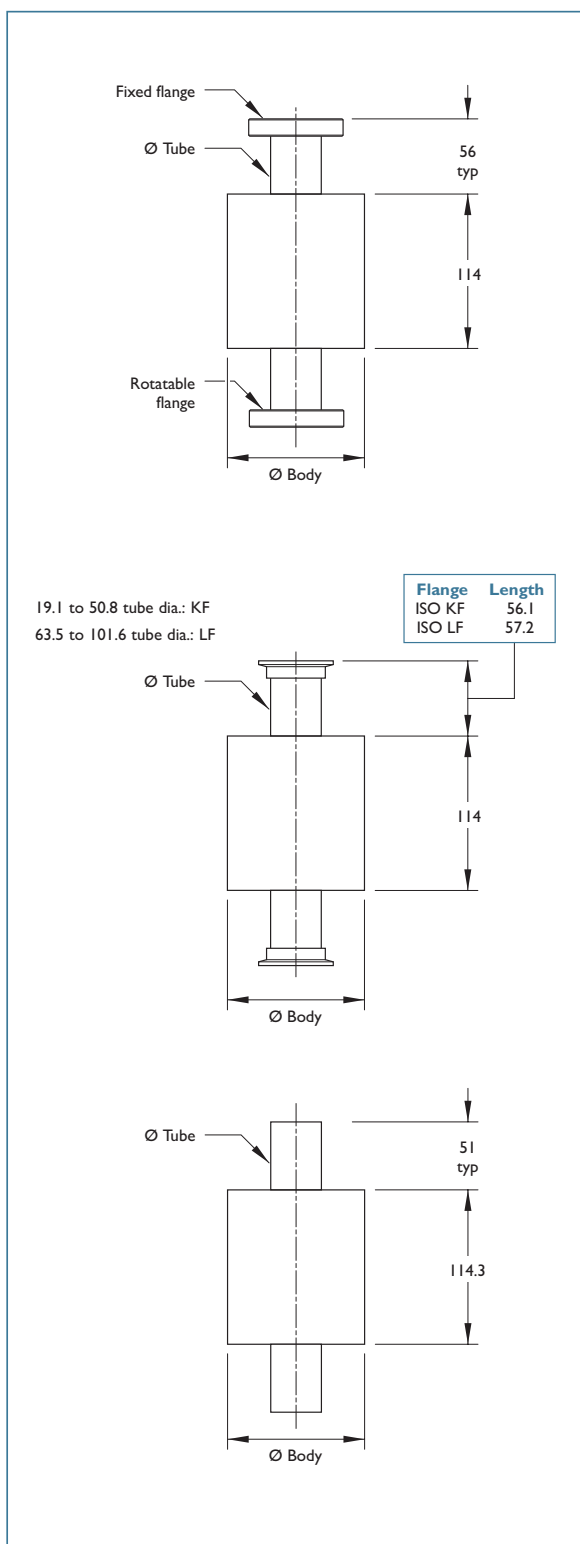

All dimensions are nominal in millimetres unless specified



CF



Trap size	Flange	Tube diameter	Body diameter	Wt kg	Reference	Part number
100	DN16CF	19.1	102	1.1	TX-075-2	430000
100	DN40CF	38.1	102	2.0	TX-150-2	430006

ISO KF



Trap size	Flange	Tube diameter	Body diameter	Wt kg	Reference	Part number
100	DN16KF	19.1	102	1.1	KTX-075-2	430050
100	DN25KF	25.4	102	1.4	KTX-100-2	430051
100	DN40KF	38.1	102	2.0	KTX-150-2	430052
100	DN50KF	50.8	102	2.3	KTX-200-2	430053
100	DN63KF	63.5	102	2.3	LTX-250-2	430054
150	DN100LF	101.6	152	3.0	LTX-400-2	430055

Hose connection



Trap size	Tube diameter	Body diameter	Wt kg	Reference	Part number
100	19.1	102	1.2	TX-075	430002
100	38.1	102	2.0	TX-150	430008
100	50.8	102	2.3	TX-200	430011
100	63.5	102	2.3	TX-250	430014
150	101.6	152	3.0	TX-400	430020

All dimensions are nominal in millimetres unless specified Weights given are approximate



Foreline traps

Coaxial with replaceable filter

Foreline traps



UHV and HV series

Features

- Significantly reduces oil backstreaming
- Two-piece clamped body design for easy element replacement
- Choice of copper, stainless steel, bronze, activated alumina and activated carbon filter elements
- 50mm to 200mm body diameters
- 304 stainless steel trap body
- Viton® O-ring body seal

Description

In contrast to the single-piece units on the previous two pages, the two-piece coaxial foreline traps offer a wider selection of filter element materials. Filter elements for a two-piece trap are removable stainless steel screen cartridges filled with copper, stainless steel or bronze wools, activated alumina, activated carbon or dual element absorbent material.

During operation, pump oil coalesces on the element and returns to the pump. Activated alumina effectively adsorbs acids and water vapour, while activated carbon adsorbs organics and water vapour. Filter cartridges are quickly and easily replaced by removing the banded clamp that fastens the two-piece body. Caburn-MDC recommends keeping a spare element on-hand for a quick change to minimize down time. Re-usable elements may be cleaned and ready for the next exchange.

Two-piece traps are offered with 50, 100, 150 and 200mm body diameters. All coaxial trap bodies are made of type 304 stainless steel and are offered with a choice of hose or flange style connections. CF metal seal flange connections have one fixed and one rotatable flange for alignment purposes. ISOKF and ISOLF flanges are clamp-style. Hose connections may also be welded, but permanent installation must be carefully evaluated. Contaminated traps may be cleaned with a solvent and allowed to dry before replacing into service. Filter elements are not included with trap assemblies; they must be ordered separately from the tables on page 191.

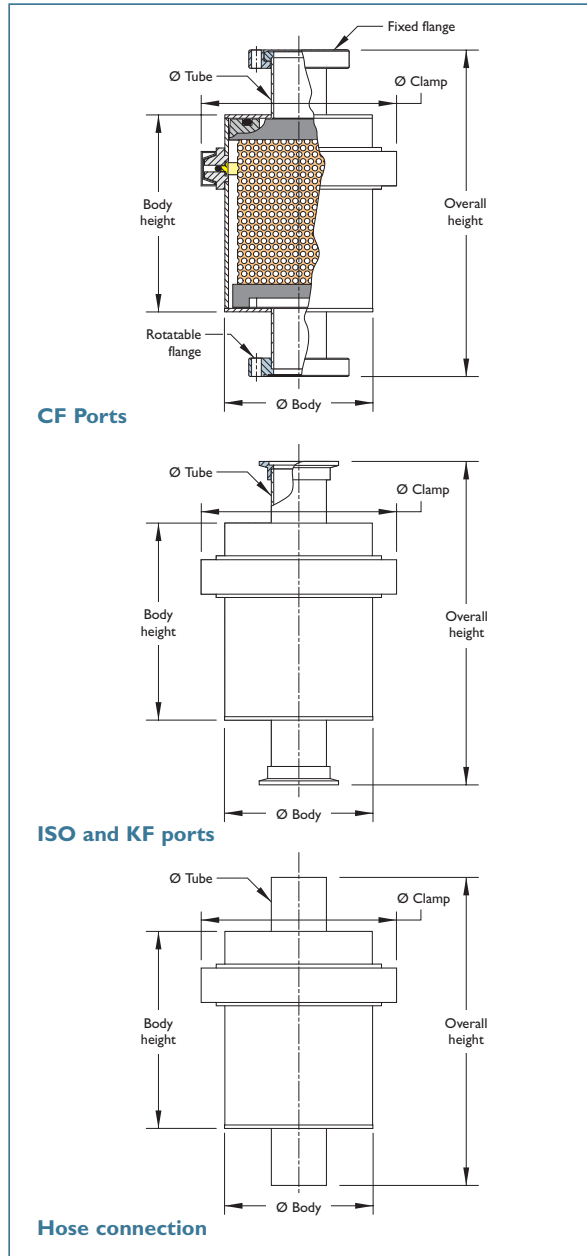

All dimensions are nominal in millimetres unless specified



Foreline traps

Coaxial with replaceable filter



Foreline traps

CF



Trap size	Flange	Tube dia.	Body dia.	Body height	Overall height	Clamp 00	Wt kg	Reference	Part number
50	DN16CF	19.1	51	135	237	115	0.9	DFT-2075-2	433002
100	DN40CF	38.1	102	135	222	137	2.3	DFT-4150-2	433014
150	DN63CF	114.3	150	180	275	184	7	DFT-6250-2	433026

ISO KF and ISO LF



Trap size	Flange	Tube dia.	Body dia.	Body height	Overall height	Clamp 00	Wt kg	Reference	Part number
50	DN16KF	19.1	51	135	237	115	0.9	KDFT-2075-2	433003
50	DN25KF	25.4	51	135	220	115	0.9	KDFT-2100-2	433006
100	DN16KF	19.1	102	135	237	137	2.3	KDFT-4075-2	433009
100	DN25KF	25.4	102	135	220	137	2.3	KDFT-4100-2	433012
100	DN40KF	38.1	102	135	222	137	2.3	KDFT-4150-2	433015
100	DN50KF	50.8	102	135	223	137	2.3	KDFT-4200-2	433018
150	DN40KF	38.1	153	180	266	184	6.8	KDFT-6150-2	433021
150	DN50KF	50.8	153	180	267	184	6.8	KDFT-6200-2	433024
150	DN63LF	63.5	153	180	269	184	6.8	LDFT-6250-2	433027
200	DN63LF	63.5	203	256	345	243	11.4	LDFT-8250-2	433033
200	DN100LF	101.6	203	256	345	243	11.4	LDFT-8400-2	433039
200	DN160LF	152.4	203	256	345	243	11.4	LDFT-8600-2	433042

Hose connection



Trap size	Tube diameter	Body diameter	Body height	Overall height	Clamp 00	Wt kg	Reference	Part number
50	19.1	51	135	210	115	0.9	DFT-2075	433001
100	38.1	102	135	210	137	2.3	DFT-4150	433013

All dimensions are nominal in millimetres unless specified Weights given are approximate

Foreline traps

Filter elements

Filters for two-piece coaxial traps



Features

- Easy exchange of cartridges
- Metal sieve units are reusable
- Use with two-piece coaxial trap bodies

Description

Two-piece coaxial foreline traps offer a wide selection of replaceable filter element materials. Filter elements for a two-piece trap are removable stainless steel screen cartridges filled with copper, stainless steel or bronze wools, activated alumina, activated carbon or dual element absorbent material.

Metal wool filter elements are used primarily for the trapping of pump oil backstreaming through a vacuum system. During pump operation, oil coalesces on the metal wool element and drains back to the vacuum pump. Activated alumina effectively adsorbs both acids and water vapour while activated carbon adsorbs organics and water vapour. The selection chart at the bottom of the facing page will help in choosing a filter element for your specific application.

Filter cartridges are quickly and easily replaced by removing the banded clamp that fastens a two-piece coaxial trap body. To minimize down time, Caburn-MDC recommends keeping spare filter elements on-hand for quick replacement. Re-usable elements may be cleaned and stored for the next exchange. With the exception of the activated carbon and dual element filters, all others are re-usable. Filter elements are not included with trap assemblies and must be ordered separately using the part numbers detailed on the next page. Filters for 50, 100, 150 and 200mm body diameters are included. Contaminated elements may be cleaned with a solvent and allowed to dry before re-using.

All dimensions are nominal in millimetres unless specified

Caburn-MDC Europe Limited Telephone +44 (0)870 428 7646 www.caburn.co.uk



Foreline traps

Filter elements



Foreline traps



	Reference	Part number
Use with 50mm body traps		
Copper sieve element	DFT-2F-CU	433050
Stainless steel sieve element	DFT-2F-SS	433051
Bronze sieve element	DFT-2F-BR	433052
Activated alumina cartridge ²	DFT-2F-AA	433053
Activated carbon cartridge ²	DFT-2F-AC	433054
Use with 100mm body traps		
Copper sieve element	DFT-4F-CU	433055
Stainless steel sieve element	DFT-4F-SS	433056
Bronze sieve element	DFT-4F-BR	433057
Activated alumina cartridge ²	DFT-4F-AA	433058
Activated carbon cartridge ²	DFT-4F-AC	433059
Dual element ac/fg ^{1,2}	DFT-4F-DE	433060
Use with 150mm body traps		
Copper sieve element	DFT-6F-CU	433061
Stainless steel sieve element	DFT-6F-SS	433062
Bronze sieve element	DFT-6F-BR	433063
Activated alumina cartridge ²	DFT-6F-AA	433064
Activated carbon cartridge ²	DFT-6F-AC	433065
Dual element ac/fg ^{1,2}	DFT-6F-DE	433066
Use with 200mm body traps		
Copper sieve element	DFT-8F-CU	433067
Stainless steel sieve element	DFT-8F-SS	433068
Bronze sieve element	DFT-8F-BR	433069
Activated alumina cartridge ²	DFT-8F-AA	433070
Activated carbon cartridge ²	DFT-8F-AC	433071

¹ Activated carbon and fibreglass
² Requires initial pump-down

Filter element selection table

	Stainless steel	Copper	Bronze	Activated alumina	Activated carbon	Dual element	
Prevent oil back-streaming	***	***	***	•	•	***	Effective rating *** Very good ** Good • Fair
Trap water vapour				**	**		
Trap organics					***	***	
Trap acid vapours				***			

This table is offered as a general guideline for filter selection



Foreline traps

Liquid nitrogen

Foreline traps



UHV and HV series

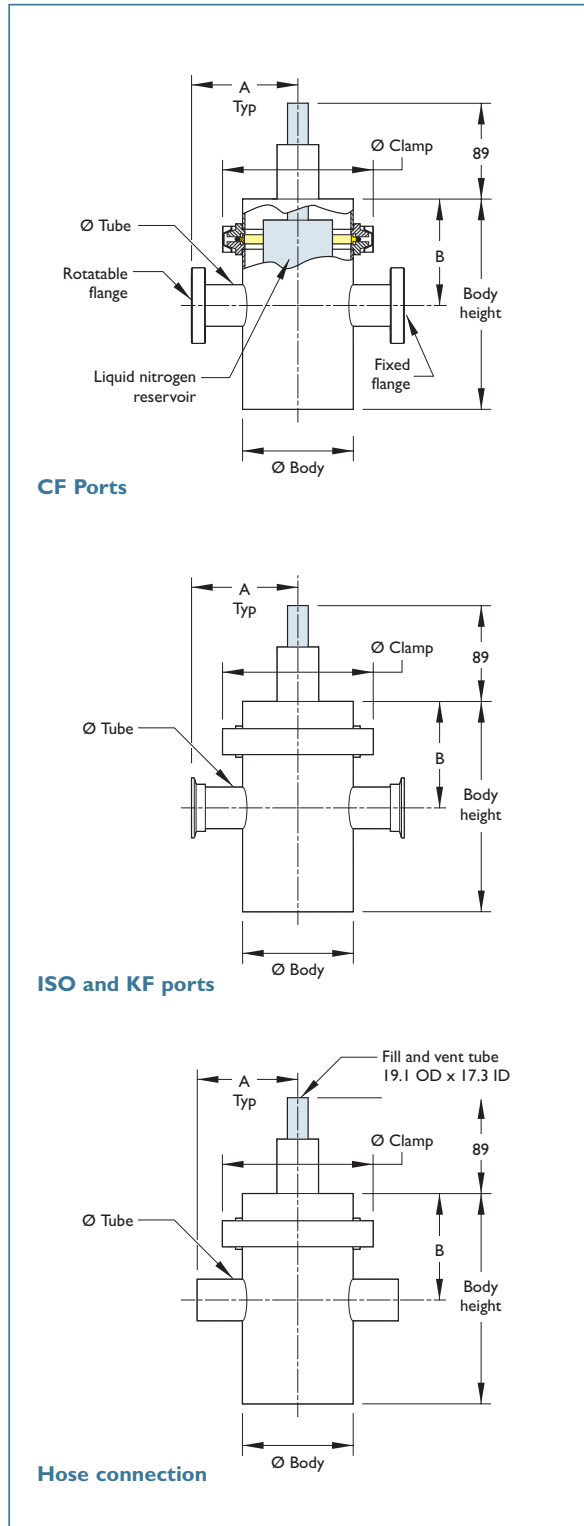

Features

- Traps all types of condensable vapours
- Two-piece, clamped body for easy maintenance
- 304 stainless steel trap body
- Aluminium centring ring with Viton® O-ring
- Low LN₂ consumption

Description

Liquid nitrogen traps remove condensables before they enter the pump or backstream from the pump to the vacuum system. Water trapping by the liquid nitrogen cooled stainless steel surface is complete and permanent.

Liquid nitrogen is added to the reservoir through a fill and vent tube at the top of the trap. A liquid level sensor from a customer-supplied controller can also be inserted through the tube. Reservoir capacities, given in litres, are listed in the product tables.

Liquid nitrogen consumption is largely dependent on the level of vacuum maintained in the roughing line. Other factors such as frequency of vacuum cycling, ambient relative humidity and gas bleed also affect consumption. Regeneration is achieved by isolating the trap from the vacuum system and removing the band clamp to separate the upper and lower body sections.

All dimensions are nominal in millimetres unless specified



Foreline traps

Liquid nitrogen



Foreline traps

CF



Trap size	Nom. cap.	Flange	Tube dia.	Body dia.	Body height	A	B	Clamp 00	Wt kg	Reference	Part number
100	.45	DN16CF	19	102	192	102	98	140	2.7	DFT-4075-2LN	434001
100	.45	DN40CF	38	102	192	94	98	140	2.7	DFT-4150-2LN	434007
150	1.59	DN40CF	38	152	261	119	145	190	5.2	DFT-6150-2LN	434010
150	1.59	DN63CF	63	152	261	124	145	190	5.2	DFT-6250-2LN	434016
200	4.13	DN63CF	63	203	286	149	159	244	10.5	DFT-8250-2LN	434019
200	4.13	DN100CF	102	203	286	151	159	244	10.5	DFT-8400-2LN	434025

ISO KF and ISO LF



Trap size	Nom. cap.	Flange	Tube dia.	Body dia.	Body height	A	B	Clamp 00	Wt kg	Reference	Part number
100	.45	DN16KF	19.1	102	192	102	98	140	2.7	KDFT-4075-2LN	434002
100	.45	DN25KF	25.4	102	192	94	98	140	2.7	KDFT-4100-2LN	434005
100	.45	DN40KF	38.1	102	192	94	98	140	2.7	KDFT-4150-2LN	434008
150	1.59	DN40KF	38.1	152	261	120	146	191	5.9	KDFT-6150-2LN	434011
150	1.59	DN50KF	50.8	152	261	120	146	191	5.9	KDFT-6200-2LN	434014
150	1.59	DN63LF	63.5	152	261	121	146	191	5.9	LDFT-6250-2LN	434017
200	4.13	DN63LF	63.5	203	286	146	159	244	11.4	LDFT-8250-2LN	434020
200	4.13	DN100LF	101.6	203	286	146	159	244	11.4	LDFT-8400-2LN	434026

Hose connection



Trap size	Nom. cap.	Flange	Body dia.	Body height	A	B	Clamp 00	Wt kg	Reference	Part number
100	.45	19.1	102	192	89	98	140	2.7	DFT-4075-LN	434000
100	.45	25.4	102	192	89	98	140	2.7	DFT-4100-LN	434003
100	.45	38.1	102	192	89	98	140	2.7	DFT-4150-LN	434006
150	1.59	38.1	152	261	114	146	191	5.9	DFT-6150-LN	434009
150	1.59	50.8	152	261	114	146	191	5.9	DFT-6200-LN	434012
150	1.59	63.5	152	261	114	146	191	5.9	DFT-6250-LN	434015
200	4.13	63.5	203	286	140	159	244	11.4	DFT-8250-LN	434018
200	4.13	101.6	203	286	140	159	244	11.4	DFT-8400-LN	434024

All dimensions are nominal in millimetres unless specified Weights given are approximate

Vacuum pumps

Cryogenic sorption



Features

- 1×10^{-3} mbar vacuum level
- Economical roughing source
- No moving parts
- Vibration free operation
- Heat regeneration
- Positive pressure safety vent
- Multiple pump capability
- Clean and non-contaminating operation

Sorption roughing pumps or sorption pumps are used for pumping systems from atmospheric pressure to a pressure of approximately 10^{-2} mbar. They rely on the dispersion forces existing between a gas and a surface to bind gas molecules on chilled surfaces inside the pump. In other words, they pump by cryosorption.

Sorption pumps typically consist of a cylindrical canister or body that is filled with an adsorbent material. The adsorbent is usually a molecular sieve material, or zeolite, which consists of pellets made of a calcium or a sodium aluminosilicate crystalline matrix. The canister is placed in a dewar cooled by liquid nitrogen. Zeolite is a poor heat conductor, so an array of aluminium fins inside the pump is used to improve thermal contact with the sieve material. The pump body and internal cooling fins are specially designed for maximum heat transfer. The pump neck and flange are made of stainless steel. The pump is mounted and supported by the flanges and since stainless steel is a poor thermal conductor, frosting of adjacent components is minimized. Sorption pumps need liquid nitrogen to operate and, as with any capture pump, they have to be periodically regenerated. Sorption pumps are very clean, non-contaminating roughing pumps and are ideal for low-throughput applications. They are used in conjunction with getter pumps, ion pumps, or mechanical cryopumps.

In a sorption pump, molecules are held on the zeolite surface by physical adsorption. The number of molecules that can be held on an adsorbent is dependent on the temperature of both

gas and surface, the chemical nature of gas and surface, the microscopic roughness of the surface, and the incident flux of molecules. The key is to have equilibrium conditions such that practical amounts of gas can be captured at the desired pressures. It follows that a large surface area at low temperatures will have the capability of adsorbing large volumes of gas. By providing large surface areas, practical amounts of nitrogen can be pumped. The key elements of a sorption pump include an aluminium body, an array of fins that remove heat from the zeolite, and a pressure relief mechanism. All Caburn-MDC sorption pumps are fitted with an elastomer stopper that automatically releases positive pressure. When a sorption pump is saturated with air and allowed to warm up to room temperature, very high pressures can be generated. The elastomer stopper is a key safety element of Caburn-MDC sorption pumps and operation of this stopper should never be obstructed or disabled.

The adsorbent used is a type 5A synthetic zeolite molecular sieve material. Zeolite is a highly porous material with a surface to volume ratio of about 800 square meters per cubic centimetre. It is supplied in pellets of about 1.6mm in diameter with molecular sized cavities that are linked by 5 Angstrom size pores. These pores are large enough to trap nitrogen, oxygen, and argon molecules, the main constituents of air. Zeolite also has a very high affinity for water vapour. Water vapour accumulated



All dimensions are nominal in millimetres unless specified. Weights given are approximate.

Caburn-MDC Europe Limited Telephone +44 (0)870 428 7646 www.caburn.co.uk





through repeated pump cycles of a chamber filled with ambient air will eventually saturate the sieve material, reducing and eventually eliminating its capacity for adsorbing nitrogen and oxygen.

To remove the accumulated water and regenerate the adsorbent material, the pump must

then be baked to 250°C or higher. Under normal operating conditions, the sieve material can be recycled indefinitely.

During pump operation, do not run the heater while it's immersed in liquid nitrogen.

Noble gases, such as neon and helium are pumped poorly by sorption pumps. For instance, if neon is pumped together with air, its capacity will be less because the neon will be replaced by the active air gases, starting at pressures below 7.5 mbar. For this reason, sorption pumps are quite often staged.

When two pumps are staged, one pump is used to achieve a pressure of 7.5 mbar and is then valved off. The second pump is then opened and the pressure is further reduced. By this method, 99% of the air is removed with the first pump, and noble gases are also swept into this pump and cannot backstream into the system when pressure is further reduced. Staged, or multiple pump-assemblies are fitted with both Bourdon and thermocouple vacuum gauge tubes for monitoring vacuum levels. These manifolds are supplied with three manual UHV angle valves which allow the isolation of each pump and the manifold from the main vacuum system.

Pump operation is simple and fast. To begin pumping, add liquid nitrogen to the dewars. No electrical power is required and there are no moving parts and no vibration. A single sorption pump can evacuate a 100 litre chamber from atmosphere to 10⁻² mbar in approximately 10 minutes. Each sorption pump has a capacity of 60,000 mbar/litres. Multiple pump systems are commonly used as they are faster and more efficient. Double and triple pump systems are mounted or connected to the chamber via a vacuum manifold. Single pumps, on the other hand, mount directly to a chamber. Pumpdown begins as soon as the adsorbent material in the pump is chilled with liquid nitrogen.

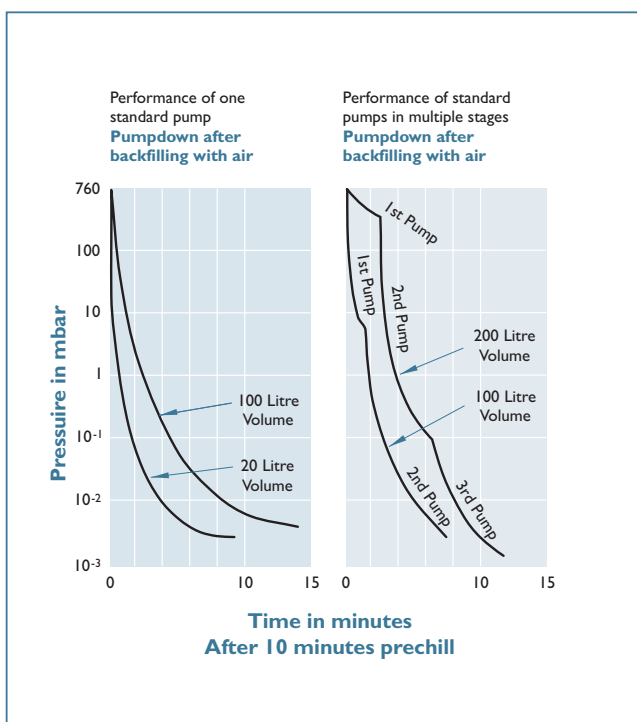
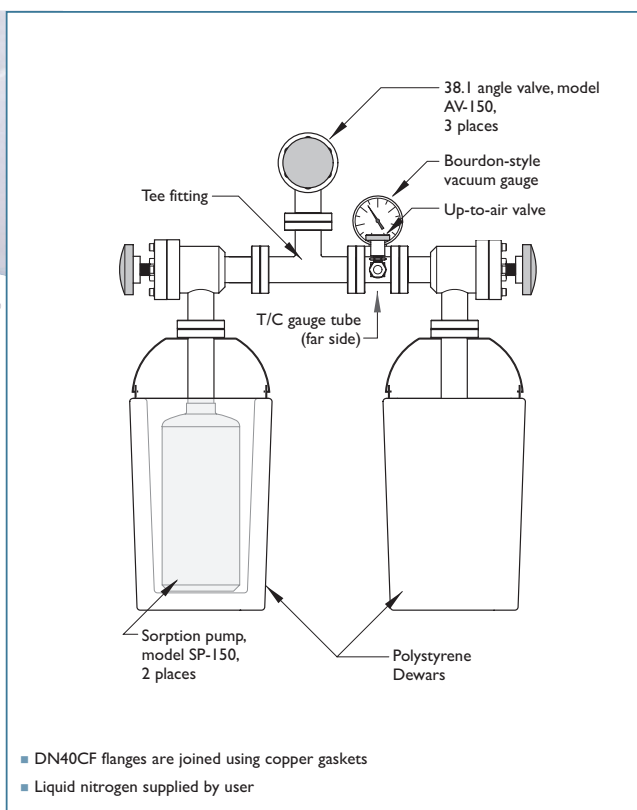

Vacuum pumps

Cryogenic sorption



Features

- Contamination-free roughing
- Requires only LN₂ for operation
- Fail-safe pressure relief valve
- Aluminium construction for high-rate heat transfer
- No moving parts – no vibration

Specifications

Material

Pump, wall and internal fins	Aluminium
Flanges	304ss
Dewar	High density rigid polystyrene

Fastening

Bolts, M6	16 Nm
-----------	-------

Vacuum range	5×10^{-3} mbar
---------------------	-------------------------

Temperature range

Pump	-210°C to 450°C
Dewar	-210°C to ambient

Weight ~ without LN₂

Single pump with Dewar added	3 kg
Double pump system	13 kg

Dimensions

See drawings

Low vacuum

Sorption pump model SP-150

Shown installed in polystyrene Dewar

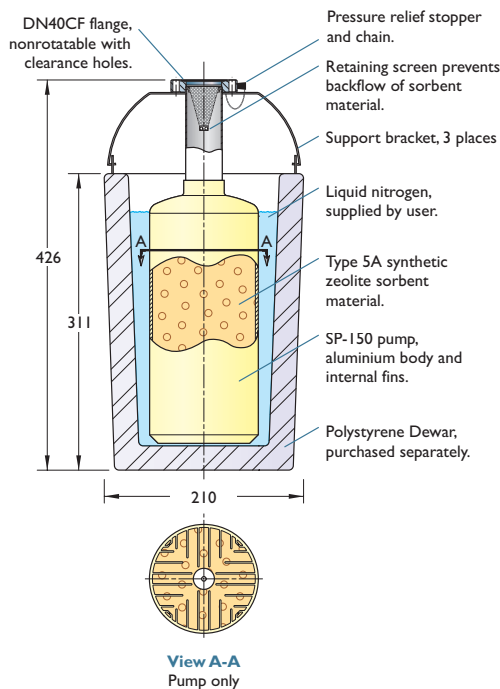

Dewar



Bakeout heater



Sorbent material



Stopper



Description	Wt kg	Reference	Part number
Dewar polystyrene	0.5	SPD-150	500001
Bakeout heater (240V)	1.8	E-SPH-150	500007
Sorbent material	1.4	SPMS-150	500003
Stopper	0.06	VSCA-18	950011

All dimensions are nominal in millimetres unless specified Weights given are approximate

Caburn-MDC Europe Limited Telephone +44 (0)870 428 7646 www.caburn.co.uk





Single pump

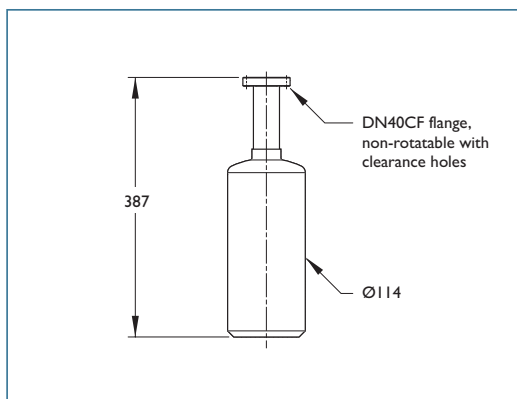

Individual pump includes

- Aluminium body with stainless steel neck
- DN40CF flange
- Includes initial sorbent material charge, copper gasket and hardware
- 3.2 kg shipping weight

Reference	Part number
SP-150	500000

Multiple pump

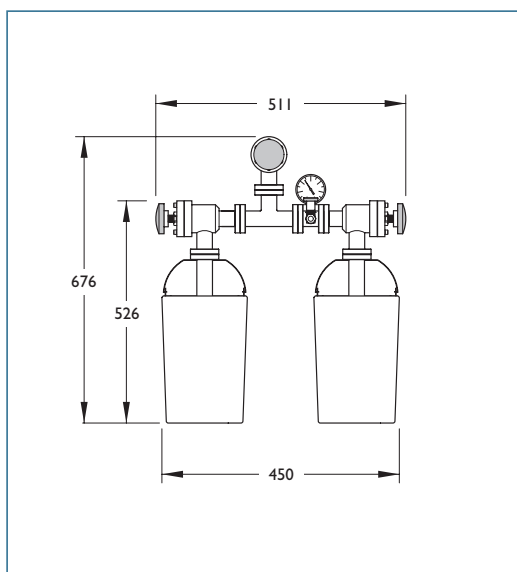

Dual system includes

- Two each SP-150 pumps with sorbent material
- Two each SPD-150 Dewars
- Three each AV-150 manual right-angle valves
- One each CFT40 tee fitting
- One each gauge nipple assembly, including thermocouple gauge tube, up-to-air valve and Bourdon vacuum gauge
- 12.7 kg shipping weight

Reference	Part number
SPS-2-150	500004

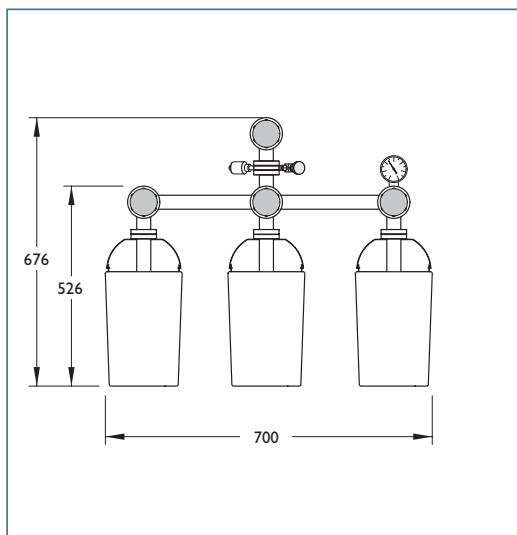

Triple system includes

- 3 each SP-150 pumps with sorbent material
- 3 each SPD-150 Dewars
- 4 each AV-150 manual right-angle valves
- 2 each CFT40 Tee fitting
- 1 each gauge nipple assembly, including thermocouple gauge tube, up-to-air valve and Bourdon vacuum gauge
- 16 kg shipping weight

Reference	Part number
SPS-3-150	500005

All dimensions are nominal in millimetres unless specified. Weights given are approximate.

Roughing components

Up-to-air-valves



UHV and HV series

Description

Caburn-MDC up-to-air valves are welded directly to a flange. The valves are 6.4mm, bellows sealed, manually activated, and have a 6.4mm (1/4") OD tube termination. They are designed for use on any type of vacuum system for venting and back fill.

Temperature range

CF configuration: -60° to 315°C

ISO KF configuration: -20° to 150°C

Features

- High-vacuum rated to 10⁻⁸ mbar
- Temperature rated to 315°C maximum with CF configuration
- Standard 6.4mm (1/4") tube end

Up-to-air valve

Shown on DN40CF flange

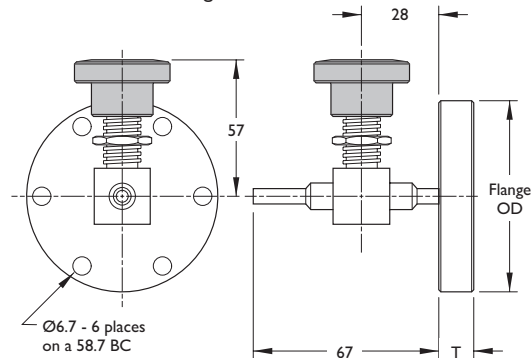

Nominal flange	Flange OD	T	Description	Wt kg	Reference	Part number
DN16CF	34	7.2	CF Flange with 6.4 up-to-air valve	0.3	F-133000-V	420009
DN40CF	70	12.7	CF Flange with 6.4 up-to-air valve	0.6	F-275000-V	420006
DN16KF	30	5	KF Flange with 6.4 up-to-air valve	0.3	K075-V	420010
DN25KF	40	5	KF Flange with 6.4 up-to-air valve	0.3	K100-V	420012
DN40KF	55	5	KF Flange with 6.4 up-to-air valve	0.4	K150-V	420013
DN50KF	75	5	KF Flange with 6.4 up-to-air valve	0.6	K200-V	420014

All dimensions are nominal in millimetres unless specified. Weights given are approximate.

Roughing components

Special flanges



UHV and HV series

Description

DN40CF double-sided flanges are supplied with no accessory holes, or with one or two 6.4mm (1/4") plain tubes for custom applications. In addition, they are offered with either one or two DNI6KF ports, up-to-air valves or a combination of both. Custom configurations are available on request.



Features

- Allows access to vacuum chambers by adding a minimum thickness to existing port
- High-vacuum rated to 10⁻⁹ mbar
- Temperature rated to 150°C maximum
- Useable with any combination of valves and gauge tubes

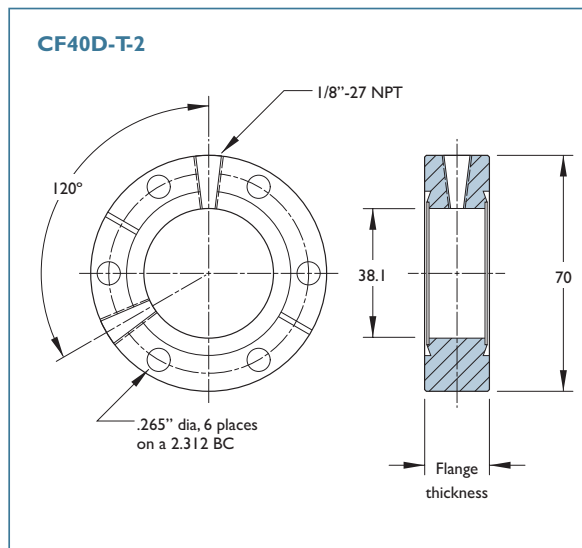

Double sided flange
2 NPT tapped holes

T/C gauge tube
Single NPT tapped hole

Up-to-air valve
Single NPT tapped hole

Tube and valve
With centre baffle

Plugs
Stainless steel 1/8\"/>



Description	T	Wt kg	Reference	Part number
Standard double sided – no accessories	19.1	0.2	CFD70-38	I40013
Extra thick (25.4mm) double sided – no accessories	25.4	0.5	CFD70-38/25	I40014
With 1 x 6.4mm (1/4) tube x 25mm long	19.1	0.5	CF40D-T	I260000
With 2 x 6.4mm (1/4) tubes x 25mm long	19.1	0.5	CF40D-T-2	I260001
With 1 x DNI6KF flange	19.1	0.5	CF40D-K16	I260002
With 2 x DNI6KF flanges	19.1	0.7	CF40D-K16-2	I260003
With metal bellows up-to-air valve	19.1	0.7	CF40D-V	I260004
DN40CF Double sided flange + K16 + valve and port	19.1	1.6	CF40D-K16-V	I260005

All dimensions are nominal in millimetres unless specified Weights given are approximate



Roughing components

Burst discs

Pressure burst disc



Features

- Positive pressure relief
- Leak tight to 2×10^{-10} mbar litres/sec
- Stainless steel body
- Compact design with no moving parts

Description

Caburn-MDC burst discs have been developed as a safety device to protect vacuum systems against back fill over-pressure. They can be used on any type of system where over-pressurization is undesirable.

When over-pressure occurs, the thin diaphragm comes in contact with the sharp edges of the housing and ruptures, relieving the pressure in the system. Once ruptured, the unit must be discarded and replaced.

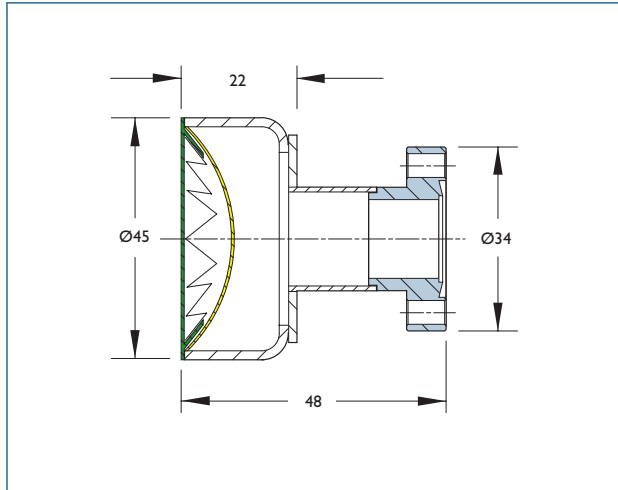

Description	Wt kg	Reference	Part number
DN16CF flange with pressure burst disc	0.3	BDA-M	7420030

Pressure burst disc with gas recovery



Features

- Positive pressure relief with DN40KF flange
- Suitable for overpressure protection of systems with hazardous gases
- Gas tight protective housing

Description

The burst disc is enclosed in a housing to prevent unwanted discharge of gas to atmosphere.

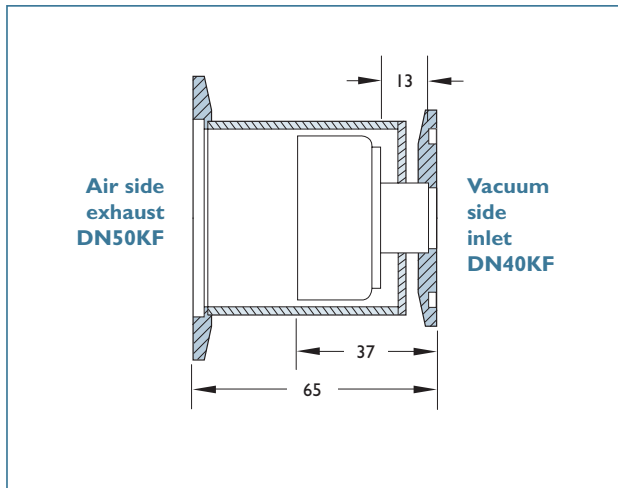

Flange	Rupture pressure	Wt kg	Reference	Part number
DN40KF	1.8 BAR	0.4	BDGR	1260101

All dimensions are nominal in millimetres unless specified Weights given are approximate

Caburn-MDC Europe Limited Telephone +44 (0)870 428 7646 www.caburn.co.uk



Roughing components

Lubricants



Roughing components

Fel-pro heavy duty anti-seize



Features

- Anti-seize for bolts used on bakeable systems
- Direct replacement for Fel-pro C-100
- Lead free – non-hazardous
- Bakeable to 1350°C
- Chemically inert to stainless steel
- Use as thread lubricant on bakeable systems
- 28g tube

Dow Corning vacuum grease DC-150



Features

- Inert, resists most chemicals
- Heat stable
- Useful temperature range -40°C to +260°C
- Low vapour pressure
- Suitable for use to 10⁻⁵ mbar
- 130g tube

Vacuum lubricant



Features

- Elastomer gasket sealant
- Gear and bearing lubricant
- High vacuum grease
- Temperature range -20°C to +300°C
- Vapour pressure mbar at 20°C < 10⁻¹³
- Fluorinated oil with fluorocarbon thickener
- 56g tube

Molybdenum disulphide (MoS₂) dry lubricant

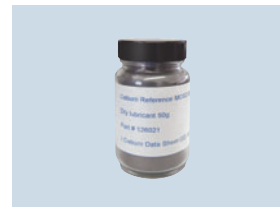

Features

- Dry lubricant hydrocarbon free
- Suitable for high vacuum and air-side use
- Temperature range -185°C to +350°C
- Micro powder (3µ) for easy surface penetration
- 50g cartons

High temperature lubricant FS-345 I



Features

- High temperature lubricant for air side use in bakeout zone
- Suitable to 230°
- Suitable for lubricating micrometers, rotary or linear drives
- Minimum temp. -40°C
- 100gm tube
- Complies with DIN51502

NB FS-345I should not be mixed with or used in conjunction with other lubricants

Apiezon vacuum grease types L and M



Features

- Hydrocarbon base allows easy clean-up with common solvents
- Suitable for use to 10⁻⁵ mbar
- 25g tube

Description	Type L	Type M
Vaporization pressure at 20°C, mbar	8 x 10 ⁻¹¹	2 x 10 ⁻⁹
Approximate melting point	47°C	44°C
Viscosity at 50°C, molten	766cP	413cP
Average molecular weight	1300	950

Description	Reference	Part number
Fel-pro heavy duty anti-seize, 28g tube	FEL-PROC-102	1260200
High temperature lubricant FS-345 I	CABLUBE	1260202
Heavy duty anti-seize lubricant, 500g can	LUBE-8009	1260209
Dow Corning vacuum grease DC-150, tube	DOW DC-150	1260203
Apiezon vacuum grease type-L, tube	APIEZON TYPE L	1260204
Apiezon vacuum grease type-M, tube	APIEZON TYPE M	1260205
Vacuum lubricant, 56g tube	KRYTOX LVP	432035
Molybdenum disulphide (MoS ₂) dry lubricant, 50g carton	MOS2-50	1260210

All dimensions are nominal in millimetres unless specified Weights given are approximate

Roughing components

Vacuum sealants and glues



Epoxy patch



Features

- Low vapour pressure resin sealant
- Seals without solvent evaporation
- Temperature range -45°C to 125°C
- Vacuum range 10^{-8} mbar
- Epoxy cement in two tubes:
 - A Resin 79g tube
 - B Hardener 34g tube

UHV Glue 1 Conducting



Features

- UHV compatible
- Two versions bakeable to 150°C or 270°C respectively
- UHV Glue is a two-component thermally and electrically conductive epoxy, it is available in two grades for medium or high temperature use
- 28g cartons

UHV Glue 2 Non-conducting



Features

- UHV compatible
- 85g cartons
- Bakeable to 150°C
- UHV Glue 2 is a two-component, thermally conductive but electrically insulating epoxy. It has been used successfully on UHV mechanisms such as AFM's at base pressures below 10^{-10} mbar
- 'Mixed' glue has 24 hour lifetime
- Must be cured at 150°C for one hour to harden

Description	Reference	Part number
Epoxy patch	EP-1	432037
UHV glue 1 conducting, maximum temperature 150°C	UHVGLUE-H21D	1260217
UHV glue 1 conducting, maximum temperature 270°C	UHVGLUE-H27D	1260218
UHV glue 2 non-conducting	UHVGLUE-H77	1260219

All dimensions are nominal in millimetres unless specified Weights given are approximate

Caburn-MDC Europe Limited Telephone +44 (0)870 428 7646 www.caburn.co.uk



Roughing components

UHV and bakeout accessories TSP tee and insert



Water-cooled TSP T-piece

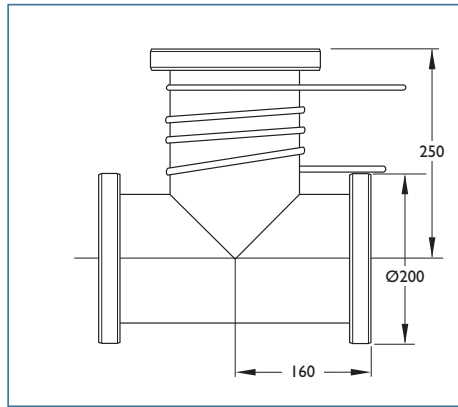

Features

- 150mm ID tube
- Water-cooled side arm
- Use with UHV pumps to enhance UHV pumping
- Custom sizes available on request

Description

DN160CF Water-cooled TSP T-piece

Reference

TSPEL 160

Part number

1280650

Liquid nitrogen TSP insert

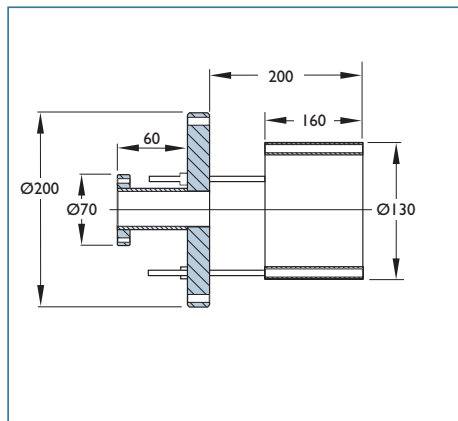
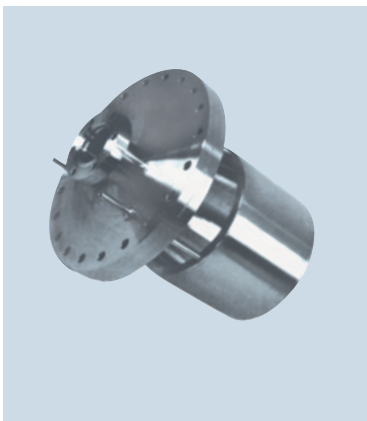

Features

- Fits into 150mm ID tube
- Two feedthrough tubes suitable for water, freon or liquid nitrogen
- Use with standard fitting CFT160
- Enhances pumping speed of TSP by an order of magnitude
- With DN40SF port

Description

DN160CF Liquid nitrogen TSP insert

Reference

TSPHI130

Part number

1280652

All dimensions are nominal in millimetres unless specified

Roughing components

UHV and bakeout accessories Flexible bakeout tents

Bakeout tents



Features

- Triple insulation layer of glass and Rayon® felt
- Typical outer material of metallized glass fibre and cloth fabric treated with polyurethane
- High resistance to wear and tear
- Excellent thermal insulation
- After four hours the outside temperature of the tent will stabilise at 50°C for 250°C inside temperature
- Custom bakeout tents can be manufactured to customer specifications, contact sales for details.

Description

Caburn-MDC is pleased to present custom-design bakeout tents comprised of a rugged but flexible new material that can be easily utilised in a large variety of custom applications.

The outer material is a composite based on a woven glass fibre fabric with a polymer polyurethane coating containing highly reflective, dispersed metal powders. This gives the fabric a combination of light weight, flexibility and resistance to abrasion and fraying.

New Velcro® fastening tabs enable the quick and convenient assembly/disassembly of the bakeout panels.

Custom design notes

Minimum hole/port diameter	80mm
Minimum slot width	10mm Closed With 'fly type' Velcro® cover
General tolerances	+20mm -0mm



Bakeout heater tape

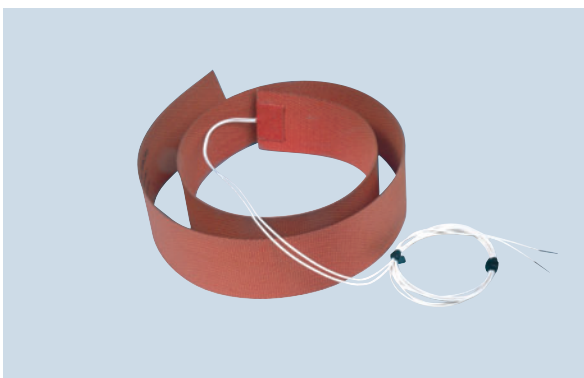

Description

Bakeout heater tape is a convenient method of heating parts of the system which are outside the main bakeout zone such as magnetic transporters or which require additional heat such as bellows to fully outgas the system.

Use the BAK93 temperature controller in conjunction with the bakeout tape and thermocouple braid.

Description	Reference	Part number
Heater tape, 240V, 400W, 1000 x 50mm	CHT1000	1280660
TC K-Type, 12 x 14mm SHIM, 1200mm metal braid	CHTK	1280661
Custom bakeout tent	Contact technical sales office	

All dimensions are nominal in millimetres unless specified

Caburn-MDC Europe Limited Telephone +44 (0)870 428 7646 www.caburn.co.uk



Roughing components

UHV and bakeout accessories **Bakeout fan unit**



Bakeout fan unit

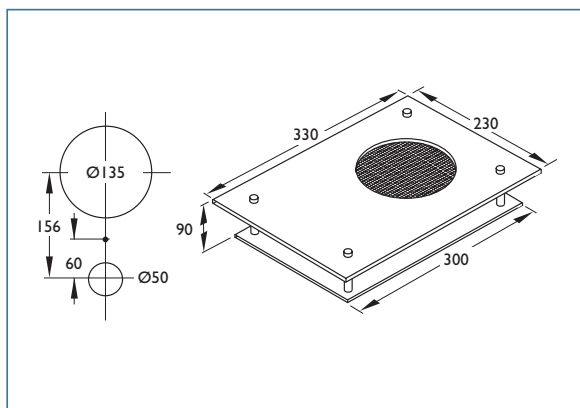
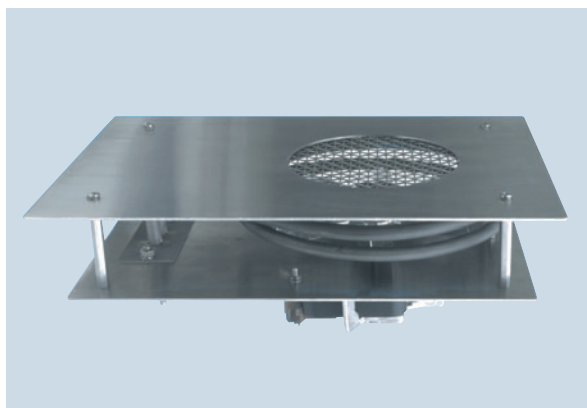

Description

The bakeout fan unit is a 2.5kW heater and fan blower unit designed to be mounted in the customer's system base or standard Caburn-MDC bench extension. Normal supply is 220-240V AC. Use the template details shown to mount the unit with an M4 bolt in the centre hole and

pass the fan motor and electrical contact points through the large holes.

The bakeout contactor kit is a 20A 220-240V AC heavy duty relay and snubber which can be used to interface the CFAN with a system controller or the BAK93 temperature controller (below).

Description	Wt kg	Reference	Part number
Bakeout fan unit	4.0	CFANI	1280670
Bakeout contactor kit	0.3	BAKCON-20	1280673

Unit temperature controller



Description

The series 93 is a rugged, water resistant microprocessor based temperature controller with single input, dual output and heat/cool autotuning.

It has a full feature set normally found only on advanced controls including heat/cool auto-tune, ramp to set point, versatile alarms and percent power limit. New hardware features include green displays and a universal low and high voltage power supply. Use in conjunction with the CFAN bakeout fan unit (above).

Features

- Compact size
- Dual digital display
- Range limiting of set point
- Operator lockout

Description	Wt kg	Reference	Part number
CFANI Temperature controller	0.3	BAK93	1280674

All dimensions are nominal in millimetres unless specified Weights given are approximate

Roughing components

UHV and bakeout accessories **Bakeout cables**

High current cables



Features

- Nickel plated copper wire
- PTFE glass braid
- PTFE dispersion coated
- Bakeable to 260°C
- Use heavy duty for TSP connections
- Custom lengths available on request

Description

Bakeable high current cables are ideal for general purpose use in the bakeout zone, connecting with bakeout heaters and a variety of other applications, including making feedthrough connections.

Description	Strands diameter	Amps maximum	Length metres	Reference	Part number
Bakeable cable	19/0.3	20	5	CFGLAS-5	1280750
Bakeable cable	19/0.3	20	10	CFGLAS-10	1280751
Bakeable cable heavy duty	133/0.3	60	5	CD7444-5	1280752
Bakeable cable heavy duty	133/0.3	60	10	CD7444-10	1280753

Bakeable coaxial cables



Features

- Graphite coated PTFE dielectric coaxial cable
- Suitable for 500V dielectric constant 30kV/mm
- High-quality, low-noise cable 50Ω
- Bakeable to 260°C
- Suitable for signal connections in the bakeout zone
- Custom lengths available on request

Description	Volts maximum	Length metres	Reference	Part number
Bakeable coaxial cable	500	5	CRGL187-5	1280756
Bakeable coaxial cable	500	10	CRGL187-10	1280757

All dimensions are nominal in millimetres unless specified

Caburn-MDC Europe Limited Telephone +44 (0)870 428 7646 www.caburn.co.uk

