

MARATHON® CP-8 CRYOPUMP



The versatile Marathon® CP-8 Cryopump was specifically designed to meet the needs of high vacuum applications ranging from custom laboratory equipment to industrial-scale deposition tools. Its innovative design assures that users achieve the highest performance possible, while keeping it competitively priced.

Depending upon the users electrical requirements, the CP-8 can be driven by either the HC-4E1, HC-8E4 or F-70 compressor. Each compressor is specifically designed for helium service and offers a unique 30,000-hour service interval.

Additionally, the optional Marathon Cryopump Controller (MCC) enables fully automatic operation of the cryopump using commands from a host computer using standard cryopump protocol. The result is greatly reduced

downtime between production cycles, improved process times and better overall efficiency of the user's process. Most importantly, by utilizing the MCC system, users can achieve rapid "cold-to-cold" times.

The CP-8's compact and robust design fits easily onto new and existing systems. The ability to service the CP-8 "in-situ" saves the user maintenance costs and downtime, and does not require removing the cryopump or breaking chamber vacuum for return or replacement. The result is maximum uptime and minimum cost of ownership. Like all SHI Cryogenics Group products, it is supported by a worldwide sales and support network.

Features

- Patented, pneumatically-driven cold head with limited moving parts for reliable operation and on-site, "in-situ" maintenance
- High capacity for longer operation
- High crossover pressure and pumping speeds for faster pumpdowns
- Drop-in replacement for existing systems
- Option for fully automatic operation and fast regeneration (i.e. superior "cold-to cold" time)

Specifications

Pumping Speeds:	Air	1,500 L/sec	Crossover Rating:	220 torr-liters		
	Water	4,200 L/sec		Cooldown:	75 minutes	
	Argon	1,250 L/sec			Inlet Flange:	ANSI 6 inch, ISO 200 mm or Conflat 10 inch
	Hydrogen	2,300 L/sec				Weight:
Throughput:	Argon	11.0 torr-liters/sec (870 sccm)				
	Capacity:	Argon	1,200 standard liters			
	Hydrogen	25 standard liters				

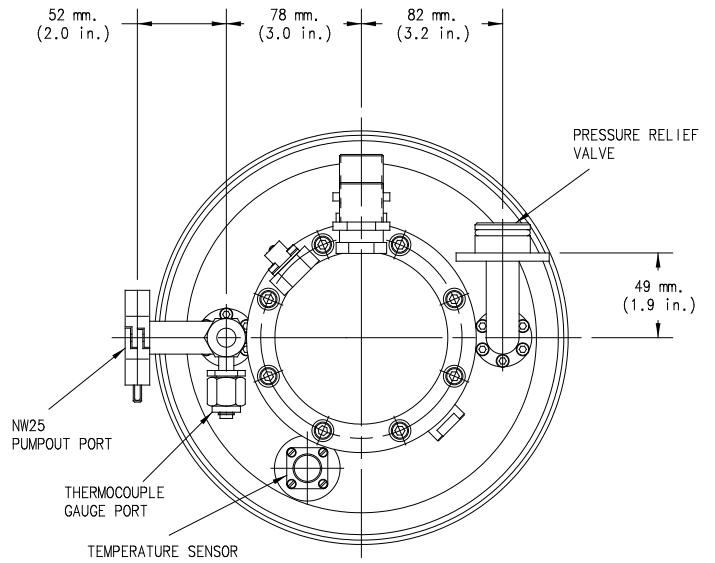
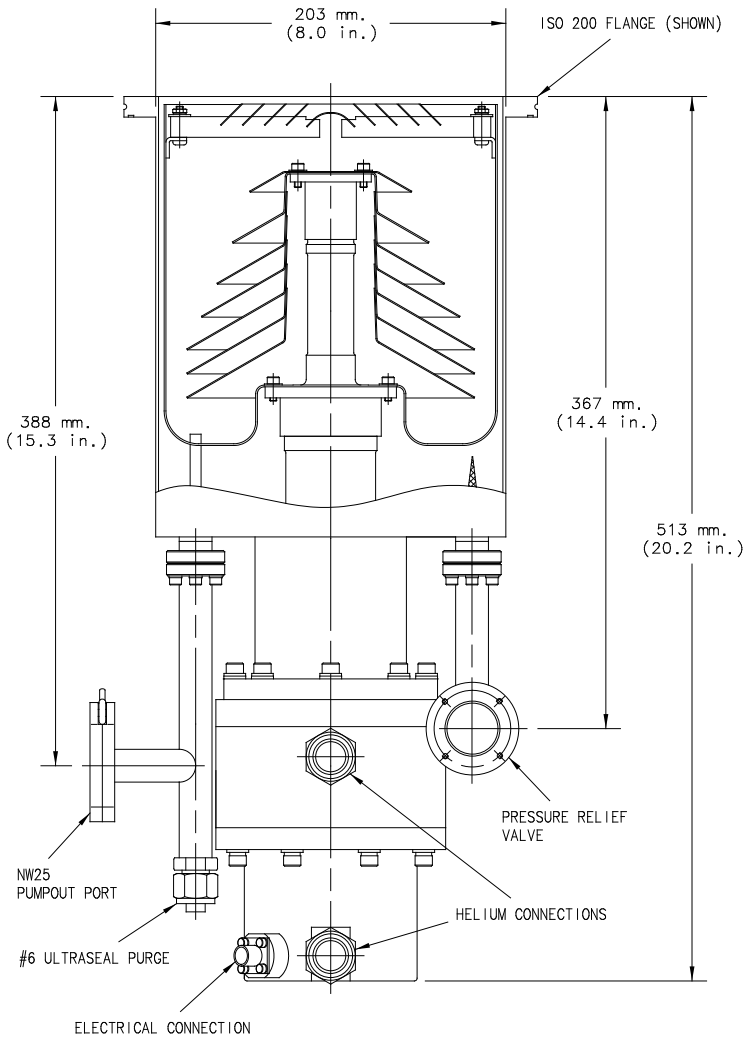

For Information in: Asia

Sumitomo Heavy Industries, Ltd.
ThinkPark Tower
Cryogenics Division, Sales Department
1-1, Osaki 2-Chome, Shinagawa-Ku
Tokyo 141-6025, Japan
Phone: +81-3-6737-2550
Fax: +81-3-6866-5114
E-mail: cryo@shi.co.jp

Sumitomo Heavy Industries (Shanghai), Ltd.
Room 1301, Xingdi Business Building
1698 Yishan Road, Minhang District
Shanghai 201103, P.R. China
Phone: +86-21-3462-7660
Fax: +86-21-3462-7661
E-mail: Jin-Lin_Gao@shi.co.jp

SHI Cryogenics of Korea Co., Ltd.
Room 619-620, Venture Valley
#958 Goseck-Dong, Kwonsun-Gu
Suwon-City, Gyeonggi-Do, South Korea
Phone: +82-31-278-3050
Fax: +82-31-278-3053
E-mail: Won_Bum_Lee@shi.co.jp

Europe

Sumitomo (SHI) Cryogenics of Europe, Ltd.
3 Hamilton Close, Houndmills Industrial Estate
Basingstoke, Hampshire RG21 6YT
United Kingdom
Phone: +44 (0) 1256 853333
Fax: +44 (0) 1256 471507
E-mail: uksales@shicryogenics.com

Sumitomo (SHI) Cryogenics of Europe, GmbH
Daimlerweg 5a
Darmstadt D-64293, Germany
Phone: +49 (0) 6151 860 610
Fax: +49 (0) 6151 800 252
E-mail: contact@sumitomocryo.de

World Wide Web: www.shicryogenics.com

United States

Sumitomo (SHI) Cryogenics of America, Inc.
1833 Vultee Street
Allentown, PA 18103
Phone: +1 610-791-6700
Fax: +1 610-791-0440
E-mail: sales@shicryogenics.com

Sumitomo (SHI) Cryogenics of America, Inc.
456 Oakmead Parkway
Sunnyvale, CA 94085
Phone: +1 408-736-4406
Fax: +1 408-736-7325

Sumitomo (SHI) Cryogenics of America, Inc.
1500-C Higgins Road
Elk Grove Village, IL 60007
Phone: +1 847-290-5801
Fax: +1 847-290-1984

© SHI Cryogenics Group 10/09