



TiTan™ 10S Ion Pump



TECHNICAL SPECIFICATIONS

Element Type	CV	DI
Pumping Speed (l/s, Nitrogen)	10	8
Starting Pressure (mbar)	$\leq 1 \times 10^{-3}$	$\leq 1 \times 10^{-3}$
Lifetime (hours @ 10^{-6} mbar)	50,000	
Ultimate Pressure (mbar)	$< 1 \times 10^{-11}$	
Maximum Baking Temperature (°C)	250 / 450 (without magnets)	
Inlet Flange	DN 35 (2.75 in.) CFR	
Weight, kg (lbs)	6 (13)	

DIMENSIONAL DETAILS*

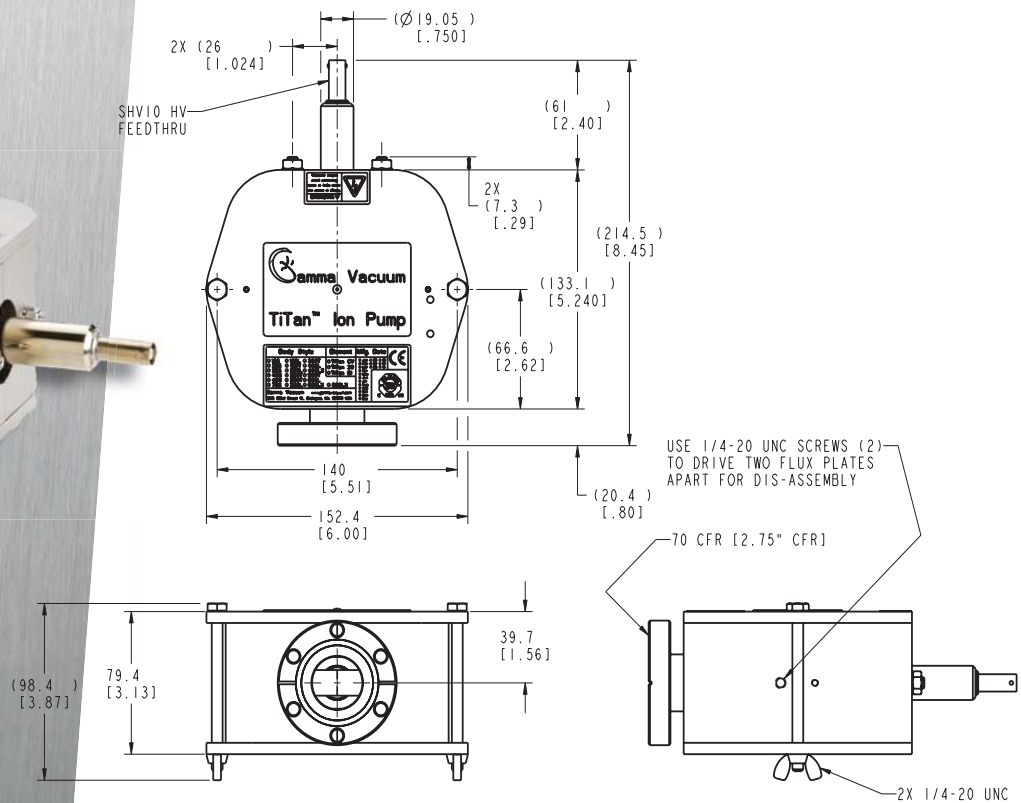

*Single inlet flange shown. Alternative configurations available at www.gammavacuum.com